

technical data sheet

type: Camino 2 DC MIL

Military Genset for fixed installation in Shelter and vehicles.

Type	CAMINO 2 DC Mil
Power:	2 kW
Voltage:	28 V
Ampere:	80 A
L/W/H incl. capsule	550 x 430 x 450 mm
Weight:	120 kg

Diesel engine 1-cylinder,
Kubota EA300, 2.600 Rpm

- Engine continuous duty 4,5 kW ICM(COP)
- Start system 12V (optional 24V)
- Fuel consumption 220g/kWh
- TA AIR

Standard equipment:

- Super sound damming cap 6-parts
All filters on maintenance side
- Asynchronous Generators short circuit proof,
Water-cooled and inclined-load-suited
- cooled exhaust system in the sound damming cap
- Ext. muffler
- Ext. Radiator inclusive electrical circulation pump and
Fan 230 V (optional tropical radiator Kima zone. A1)
- Basic panel with 5 m control line
- Electronic. engine management with battery charge
- Engine management with automatic disconnection:
to low oil pressure, to high temperatures,
loss of water
- Computer-optimised arrangement of the oscillation
absorber and integrated notice delimitation that
Rubber-bonded metals 4G in all directions
- Achievement acceptance over clamping board
- super quietly, 56 dB/A according to DIN
- Manual

Optional:

Automatic Startpanel incl. Battery monitor
Space heaters utilization that
System warmth up to 4 KW
Starting limit temperature -32°C
EMV at STANAG

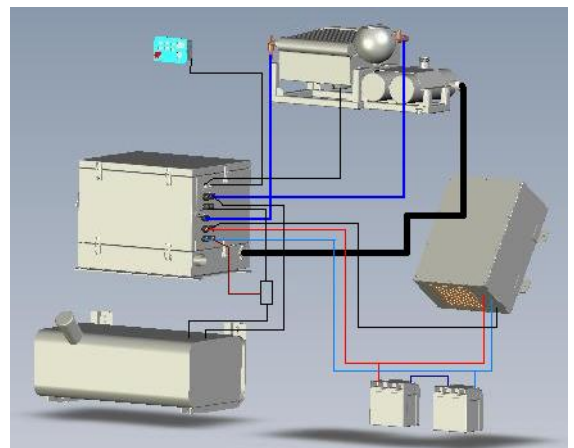
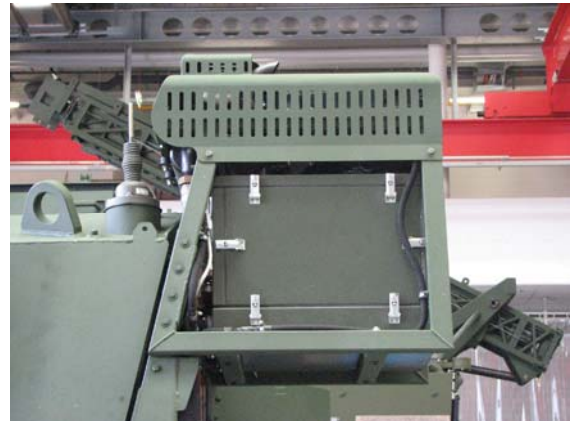

technical data sheet

type: Camino 2 DC MIL



Diese Zeichnung ist unsere Eigentum und darf gemäß den Bestimmungen des Urheberrechtes ohne unsere schriftliche Genehmigung weder kopiert noch vervielfältigt, noch dritten Personen zugänglich gemacht oder in anderer Weise missbrauchlichverwertet werden. Zuwiderhandlungen verpflichten zu Schadensersatz und können strafrechtliche folgen haben.

POS-NR.	BENENNUNG	BESCHREIBUNG	MENGE
1	23010-01	Kapsel-Unterteil kompl.	1
2	23010-02	Kapsel-Stirnwand kompl.	1
3	23010-03	Kapsel-Seitenwand kurz kompl.	1
4	23010-04	Kapsel-Seitenwand lang kompl.	1
5	23010-06	Kapsel-Anschlusswand kompl.	1
6	23010-05	Kapsel-Deckel kompl.	1

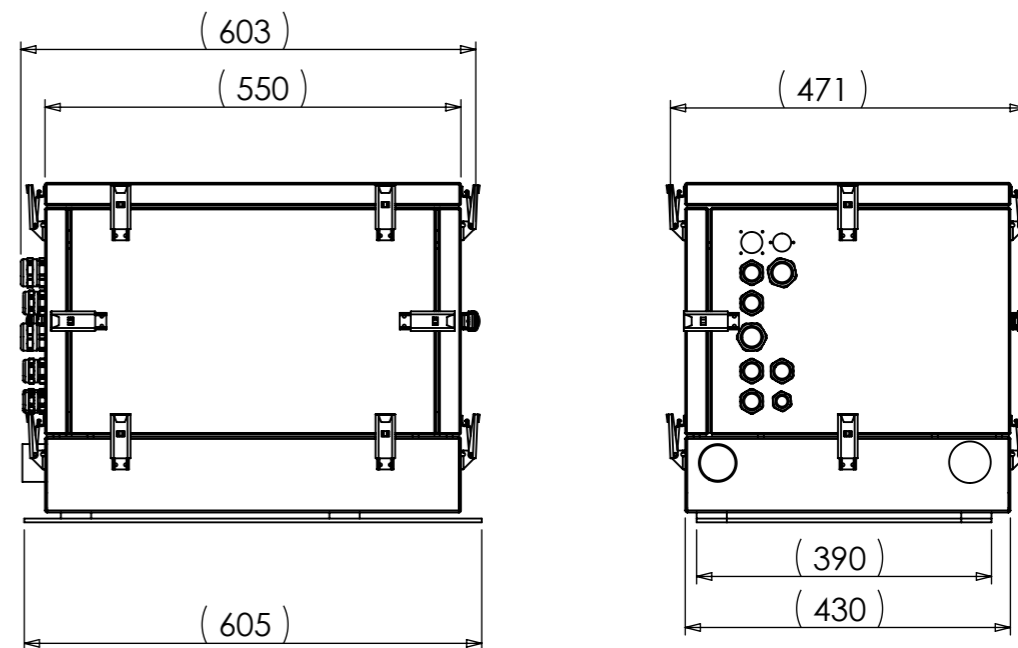
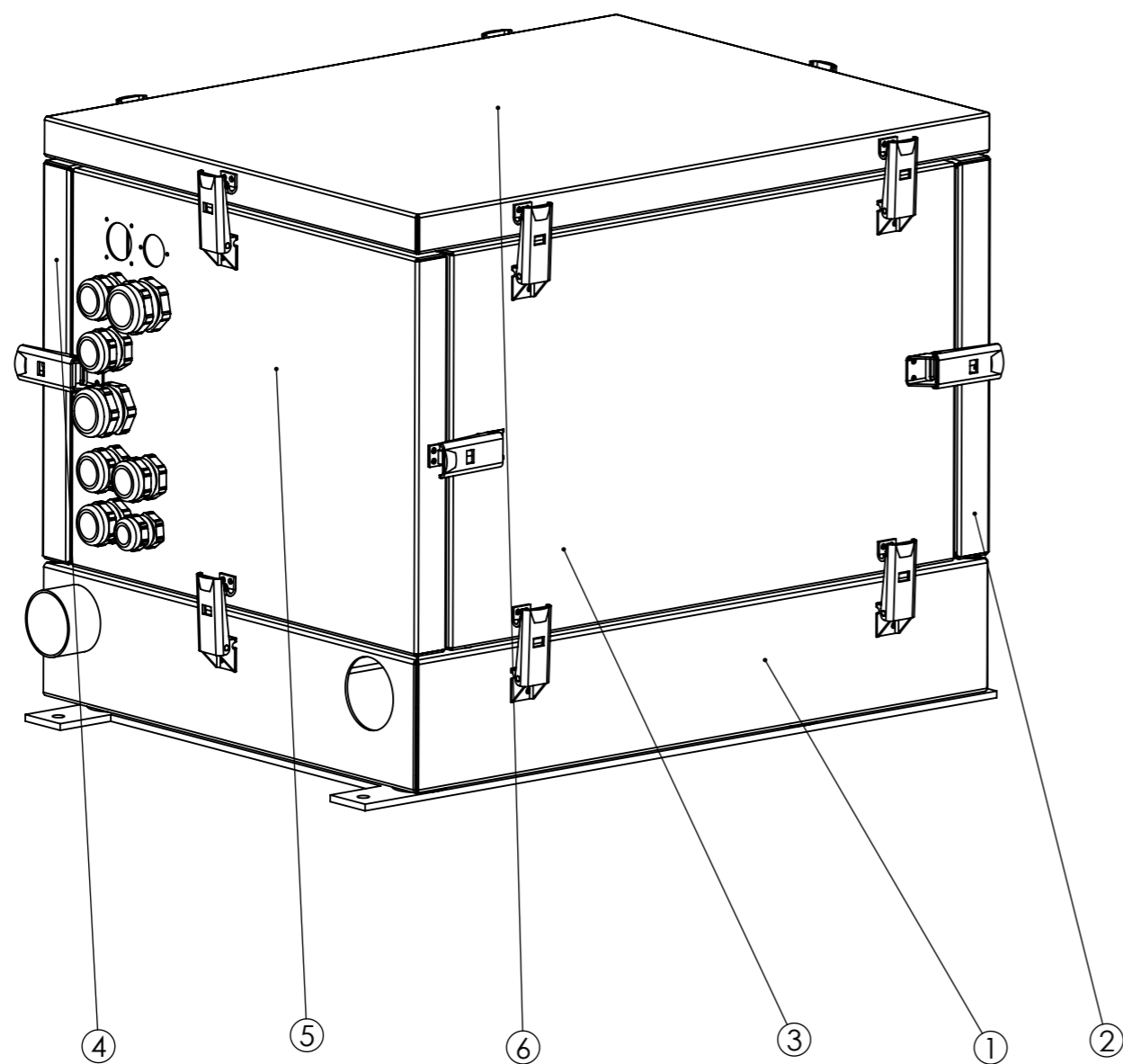

ACHTUNG
Gewichtsangabe ohne Dämmung

----Technische Änderungen vorbehalten----
Toleranz +-3mm

<p>SET Stange Energietechnik GmbH Lise-Meitner-Strasse 15 40764 Langenfeld Tel.: +492173 / 91 27 10 Fax: +492173 / 91 27 16</p>				Maßstab 1:5	ISO 2768 - m
				Werkstoff	Gewicht 30,18 kg
				Benennung Schalldämmkapsel für Camino 2 Standard	
				Zeichnungsnummer 002 002-20	
				Blatt 1 von 1 A3	
Zust.	Änderungstext	Datum	Name	Urspr.	Ers. f.
					Ers. d.