

technical data sheet

type: Camino 35 DS MIL

Military Genset for fixed installation in Shelter and vehicles.

Type	CAMINO 35 DS
Power:	30 KW / 36 KVA
Voltage:	400/230 V
Frequency:	50 Hz
Ampere:	54 A
Safety class system:	IP54
Sound:	56 dB/A according to 7m
L/B/H capsule:	1140 x 665 x 690 mm
L/B/H radiator:	710 x 230 x 810 mm
L/B/H muffler:	1000 x 130 x 500 mm
Weight:	550 kg

- Diesel engine 4 -cylinder,
Deutz D2009, 3,000 U/min.
- Engine continuous duty 36 KW ICM (COP)
 - Start system 24V
 - Fuel consumption 235g/kWh
 - TA AIR

Standard equipment:

- Super sound damming cap 6-parts
Optionally: all filters on maintenance side
- Asynchronous Generators short circuit proof,
Water-cooled and inclined-load-suited
- cooled exhaust system in the sound damming cap
- External muffler
- External Radiator inclusive electrical circulation pump and
Fan 230 V Klima zone. A1
- Basic panel with 5 m control line
- Electronic Engine management with battery charge
- Engine management with automatic disconnection:
to low oil pressure, to high temperatures,
loss of water
- Computer-optimised arrangement of the oscillation
absorber and integrated notice delimitation that
Rubber-bonded metals 4G in all directions
- Achievement acceptance over clamping board
- super quietly, 56 dB/A according to DIN
- Manual industrial

Optional:

- Climatic compressor at auxiliary drive
for climatic achievement up to 20 KW
- Space heaters utilization that
System warmth up to 30 KW
- Starting limit temperature -40°C
- EMV at STANAG



technical data sheet

type: Camino 35 DS MIL



Diese Zeichnung ist unsere Eigentum und darf gemäß den Bestimmungen des Urheberrechtes ohne unsere schriftliche Genehmigung weder kopiert noch vervielfältigt, noch dritten Personen zugänglich gemacht oder in anderer Weise missbrauchlichverwertet werden. Zuwiderhandlungen verpflichten zu Schadensersatz und können strafrechtliche folgen haben.

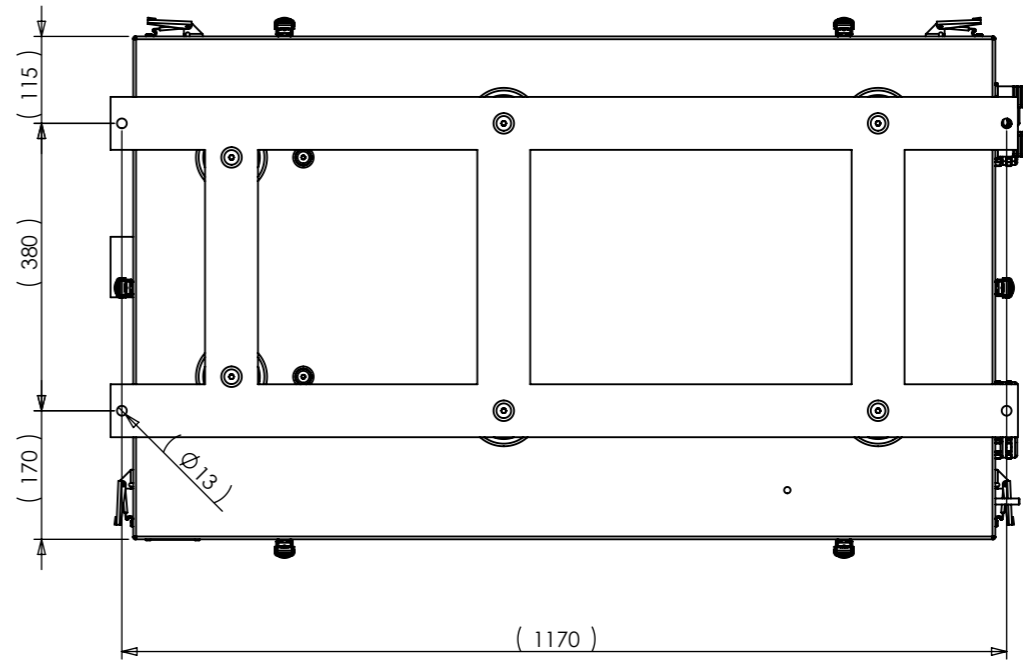
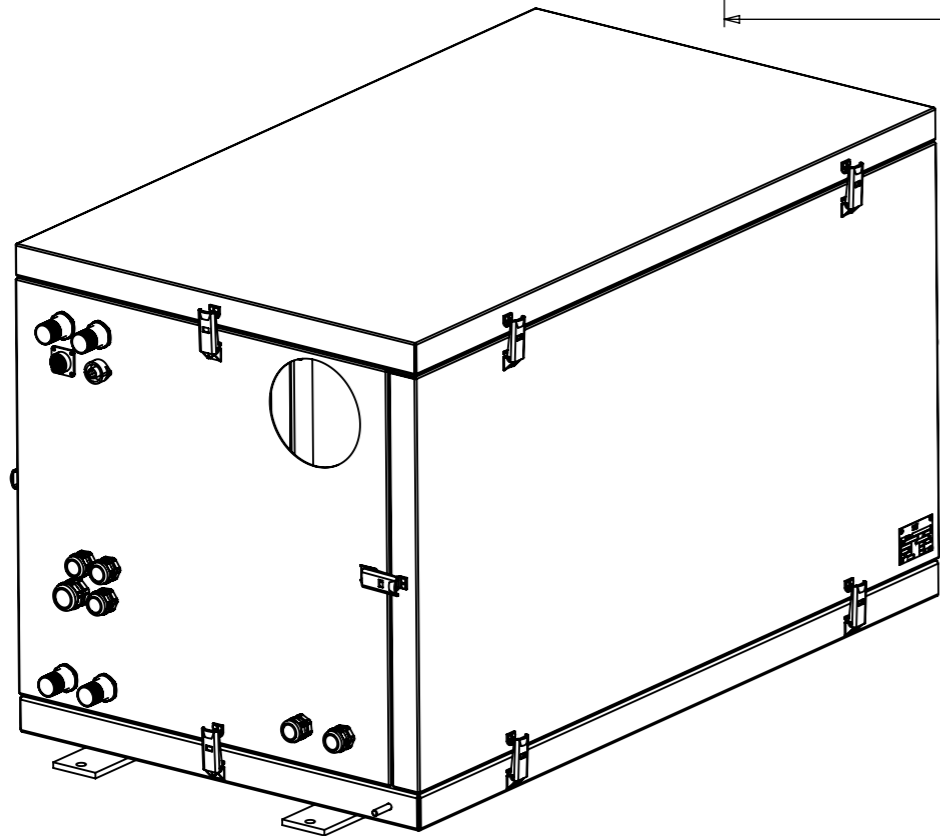
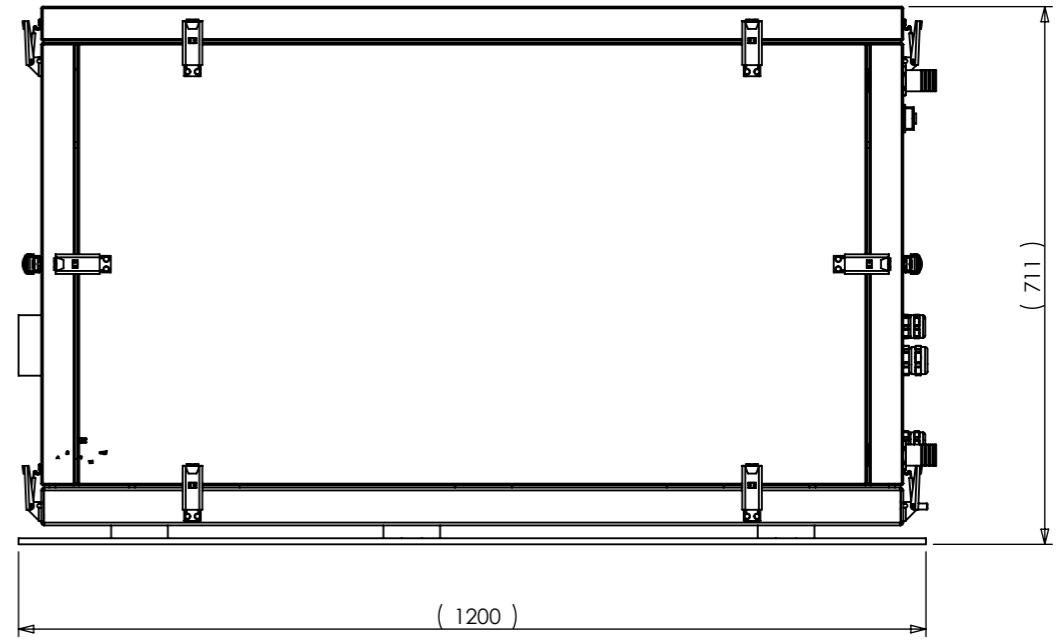
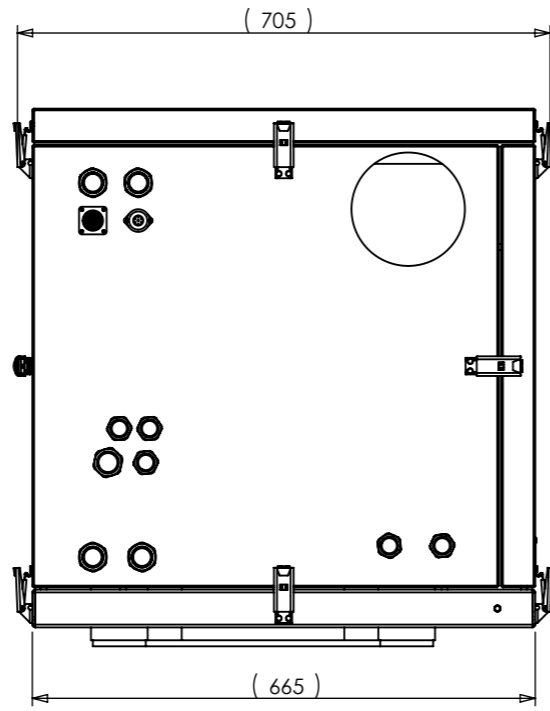

ACHTUNG
Gewichtsangabe ohne Dämmung

-----Technische Änderungen vorbehalten-----
Toleranz +3mm

POS.NR.	MENGE	ARTIKEL-NR.	BENENNUNG
1	1	23120-01	Kapsel-Unterteil kompl. Camino 35 DS
2	1	23120-06	Kapsel-Anschlusswand kompl. Camino 35 DS
3	1	23120-02	Kapsel-Deckel kompl. Camino 35 DS
4	1	23120-03	Kapsel-Seitenwand lang kompl. Camino 35 DS
5	1	23120-04	Kapsel-Seitenwand kurz kompl. Camino 35 DS
6	1	23120-05	Kapsel-Stirnwand kompl. Camino 35 DS

SET Stange Energietechnik GmbH Lise-Meitner-Strasse 15 40764 Langenfeld Tel.: +492173 / 91 27 10 Fax: +492173 / 91 27 16				Maßstab 1:10	ISO 2768 - m
				Werkstoff	Gewicht
				Benennung	
				Schalldämmkapsel kompl. Camino 35 DS	
				Zeichnungsnummer	
				23120-00	
				Blatt 1 von 1	
				A3	
Zust.	Änderungstext	Datum	Name	Urspr.	Ers. f.
					Ers. d.