

extremely silent / extremely compact / extremely efficient / extremely tough



DATA SHEETS  
CAMINO MIL

POWER GENERATOR  
FOR EXTREME CONDITIONS



### POWER GENERATORS FOR EXTREME REQUIREMENTS

extremely quiet / extremely compactly / extremely efficient / extremely robustly



**Diesel power generator CAMINO 2 MIL**  
full-encased diesel power generator  
for fixed installation in shelters and vehicles.  
Highly adaptable installation system of applications  
with low place relations, super soundproof

Power Generator Type	Camino 2 MIL
	1 ~
<b>Output</b>	
Continuous power	2 kW / 2,5 kVA
continuous current	10 A
<b>Engine</b>	
Enginetype	Kubota EA 300
Stand-by power	4,5 kW
Speed (RPM)	2.600 rpm
Governor	Mechanic
Number of cylinder	1
Coolant system	Water
Alternator	24 V
Starter	24 V
Battery (not included)	45 Ah
<b>Engine consumption</b>	
Diesel	210 g / kWh
<b>Generator</b>	
Voltage	230 V AC
Charger Voltage	24 V DC
Frequency	50 Hz
Power factor	cosφ 1/0,8
Insulation class	F
IP	54
Coolant	Water
<b>Dimensions</b>	
Length	550 mm
Width	430 mm
Height	450 mm
Weight	120 kg
Noise level	54 dB(A) @ 7 meter
<b>Accessories included</b>	
exhaust gas muffler	control panel
cooling unit	



Technical changes and mistake reserve.  
Based on the constant development and modification of the models  
can not be guaranteed that specifications comply with current models.



## POWER GENERATORS FOR EXTREME REQUIREMENTS

extremely quiet / extremely compactly / extremely efficient / extremely robustly

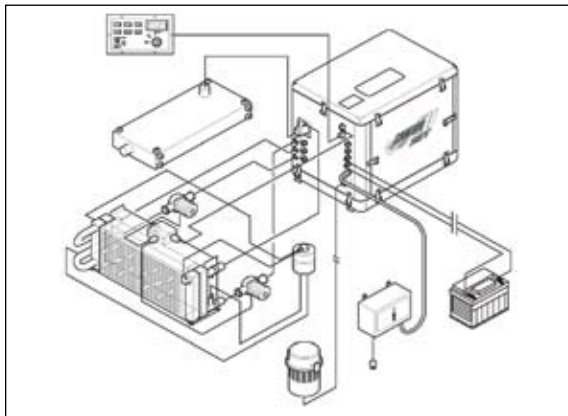

### Standard equipment

- ✓ Colour: RAL 6031
- ✓ Asynchronous generator short-circuit proof
- ✓ Super soundproof hood 6-parts
- ✓ Cooled exhaust gas routing system in the sound insulating capsule
- ✓ External exhaust gas silencer with high damping
- ✓ External radiator incl. electr. circulating pump 24 V and fan 230 V
- ✓ BASIC controlpanel incl. 5 m of control wire
- ✓ Electronic engine management with battery charge
- ✓ Engine management with automatically shut off in case of: low oil pressure, high temperature, loss of water
- ✓ Computer-optimised arrangement of the vibration dampers and integrated stop unit limitation of the rubber-bonded metals 4x inside, and 4x outside, 4G in all directions
- ✓ Super muted, extremely smooth
- ✓ Handbook industry-standard, German or English
- ✓ 24 V starting system with external start socket
- ✓ Start limit temperature -32°C
- ✓ Tropical radiator climate zone A1

### Optionally (liable to surcharge)

- Custom cooling unit possible
- Fan control dependent on temperature
- Full-electronic controlpanel with LCD and auto start system
- external air filter
- key turn ready "tunnel" on mounting base with fuel tank
- Colour: according to the arrangement
- Room heating appliance, utilisation of the system warmth 4 kw
- pre-expansion chamber
- external start socket

Technical changes and mistake reserve.  
Based on the constant development and modification of the models can not be guaranteed that specifications comply with current models.

### POWER GENERATORS FOR EXTREME REQUIREMENTS

extremely quiet / extremely compactly / extremely efficient / extremely robustly



**Diesel power generator CAMINO 4 MIL**  
full-encased diesel power generator  
for fixed installation in shelters and vehicles.  
Highly adaptable installation system of applications  
with low place relations, super soundproof

Power Generator Type	Camino 4 MIL
	1 ~
<b>Output</b>	
Continuous power	3,5 kW / 4,3 kVA
continuous current	15 A
<b>Engine</b>	
Enginetype	Farymann 18W
Stand-by power	4,8 kW
Speed (RPM)	3.000 rpm
Governor	Mechanic
Number of cylinder	1
Coolant system	Water
Alternator	24 V
Starter	24 V
Battery (not included)	45 Ah - 68 Ah
<b>Engine consumption</b>	
Diesel	210 g / kWh
<b>Generator</b>	
Voltage	230 V AC
Charger Voltage	24 V DC
Frequency	50 Hz
Power factor	cosφ 1/0,8
Insulation class	F
IP	54
Coolant	Water
<b>Dimensions</b>	
Length	530 mm
Width	410 mm
Height	510 mm
Weight	125 kg
Noise level	54 dB(A) @ 7 meter
<b>Accessories included</b>	
exhaust gas muffler	control panel
cooling unit	



Technical changes and mistake reserve.

Based on the constant development and modification of the models cannot be guaranteed that specifications comply with current models.

## POWER GENERATORS FOR EXTREME REQUIREMENTS

extremely quiet / extremely compactly / extremely efficient / extremely robustly

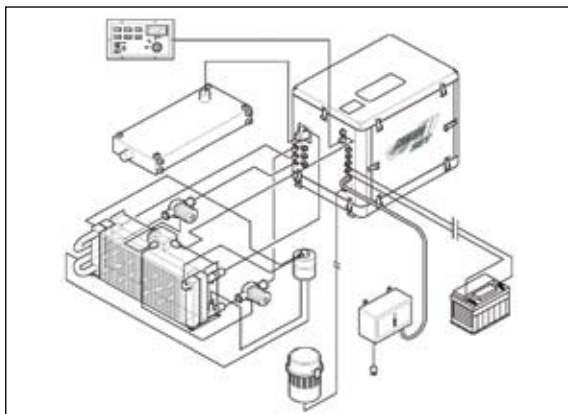

### Standard equipment

- ✓ Colour: RAL 6031
- ✓ Asynchronous generator short-circuit proof
- ✓ Super soundproof hood 6-parts
- ✓ Cooled exhaust gas routing system in the sound insulating capsule
- ✓ External exhaust gas silencer with high damping
- ✓ External radiator incl. electr. circulating pump 24 V and fan 230 V
- ✓ BASIC controlpanel incl. 5 m of control wire
- ✓ Electronic engine management with battery charge
- ✓ Engine management with automatically shut off in case of: low oil pressure, high temperature, loss of water
- ✓ Computer-optimised arrangement of the vibration dampers and integrated stop unit limitation of the rubber-bonded metals 4x inside, 4x outside, 4G in all directions
- ✓ Super muted, extremely smooth
- ✓ Handbook industry-standard, German or English
- ✓ 24 V starting system
- ✓ Start limit temperature -32°C
- ✓ Tropical radiator climate zone A1

### Optionally (liable to surcharge)

- Custom winding 400 V – 50 Hz
- Custom cooling unit possible
- Fan control dependent on temperature
- Full-electronic controlpanel with LCD and auto start system
- external air filter
- key turn ready "tunnel" on mounting base with fuel tank
- Room heating appliance, utilisation of the system warmth 5 kW
- Colour: according to the arrangement
- pre-expansion chamber
- Air compressor at auxiliary drive for climate performance to 6 kW
- Oil change interval prolongation – partial-flow filter
- external start socket

Technical changes and mistake reserve.

Based on the constant development and modification of the models cannot be guaranteed that specifications comply with current models.

### POWER GENERATORS FOR EXTREME REQUIREMENTS

extremely quiet / extremely compactly / extremely efficient / extremely robustly



**Diesel power generator CAMINO 8 MIL**  
full-encased diesel power generator  
for fixed installation in shelters and vehicles.  
Highly adaptable installation system of applications  
with low place relations, super soundproof



Power Generator Type	Camino 8 MIL
	1 ~
<b>Output</b>	
Continuous power	5,5 kW / 6,6 kVA
Continuous current	25 A
<b>Engine</b>	
Enginetype	Kubota Z 482
Stand-by power	6,9 kW
Speed (RPM)	3.000 rpm
Governor	Mechanic
Number of cylinder	2
Coolant system	Water
Alternator	24 V
Starter	24 V
Battery (not included)	45 Ah - 88 Ah
<b>Engine consumption</b>	
Diesel	260 g / kWh
<b>Generator</b>	
Voltage	230 V
Frequency	50 Hz
Power factor	cosφ 1/0,8
Insulation class	F
IP	54
Coolant	Water
<b>Dimensions</b>	
Length	650 mm
Width	500 mm
Height	600 mm
Weight	215 kg
Noise level	54 dB(A) @ 7 meter
<b>Accessories included</b>	
exhaust gas muffler	control panel
cooling unit	

Technical changes and mistake reserve.  
Based on the constant development and modification of the models cannot be guaranteed that specifications comply with current models.

## POWER GENERATORS FOR EXTREME REQUIREMENTS

extremely quiet / extremely compactly / extremely efficient / extremely robustly

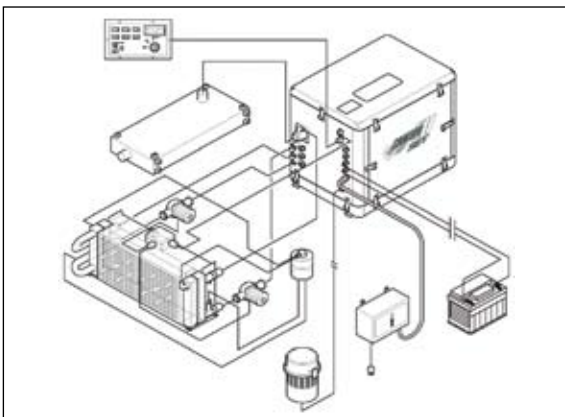

### Standard equipment

- ✓ Colour: RAL 6031
- ✓ Asynchronous generator short-circuit proof
- ✓ Super soundproof hood 6-parts
- ✓ Cooled exhaust gas routing system in the sound insulating capsule
- ✓ External exhaust gas silencer with high damping
- ✓ External radiator incl. electr. circulating pump 24 V and fan 230 V
- ✓ BASIC controlpanel incl. 5 m of control wire
- ✓ Electronic engine management with battery charge
- ✓ Engine management with automatically shut off in case of:
  - low oil pressure, high temperature, loss of water
- ✓ Computer-optimised arrangement of the vibration dampers and integrated stop unit limitation of the rubber-bonded metals
  - 4x inside, 4x outside 4G in all directions
- ✓ Super muted, extremely smooth
- ✓ Handbook industry-standard, German or English
- ✓ 24 V starting system
- ✓ Start limit temperature -32°C
- ✓ Tropical radiator climate zone A1

### Optionally (liable to surcharge)

- Custom winding 400 V – 50 Hz
- Custom cooling unit possible
- Fan control dependent on temperature
- Full-electronic controlpanel with LCD and auto start system
- external air filter
- key turn ready "tunnel" on mounting base with fuel tank
- Room heating appliance, utilisation of the system warmth to 5 kW
- Colour: according to the arrangement
- Air compressor at auxiliary drive for climate performance to 6 kW
- Oil change interval prolongation – partial-flow filter
- external start socket

Technical changes and mistake reserve.

Based on the constant development and modification of the models cannot be guaranteed that specifications comply with current models.

### POWER GENERATORS FOR EXTREME REQUIREMENTS

extremely quiet / extremely compactly / extremely efficient / extremely robustly



**Diesel power generator CAMINO 10 DS MIL**  
 full-encased diesel power generator  
 for fixed installation in shelters and vehicles.  
 Highly adaptable installation system of applications  
 with low place relations, super soundproof

Power Generator Type	Camino 10 DS MIL
	3 ~
<b>Output</b>	
Continuous power	8 kW / 10 kVA
Continuous current	12,5 A
<b>Engine</b>	
Enginetype	Lombardini FOCS Plus LDW702
Stand-by power	10,3 kW
Speed (RPM)	3.000 rpm
Governor	Mechanic
Number of cylinder	2
Coolant system	Water
Alternator	24 V
Starter	24 V
Battery (not included)	45 Ah - 88 Ah
<b>Engine consumption</b>	
Diesel	290 g / kWh
<b>Generator</b>	
Voltage	400 V / 230 V
Frequency	50 Hz
Power factor	cosφ 1/0,8
Insulation class	F
IP	54
Coolant	Water
<b>Dimensions</b>	
Length	763 mm
Width	589 mm
Height	640 mm
Weight	365 kg
Noise level	54 dB(A) @ 7 meter
<b>Accessories included</b>	
exhaust gas muffler	control panel
cooling unit	



Technical changes and mistake reserve.  
 Based on the constant development and modification of the models cannot  
 be guaranteed that specifications comply with current models.



## POWER GENERATORS FOR EXTREME REQUIREMENTS

extremely quiet / extremely compactly / extremely efficient / extremely robustly

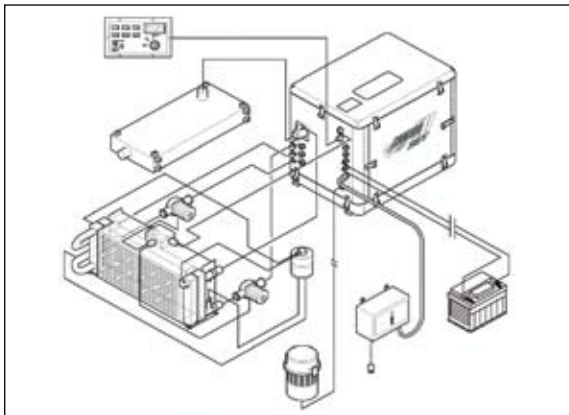
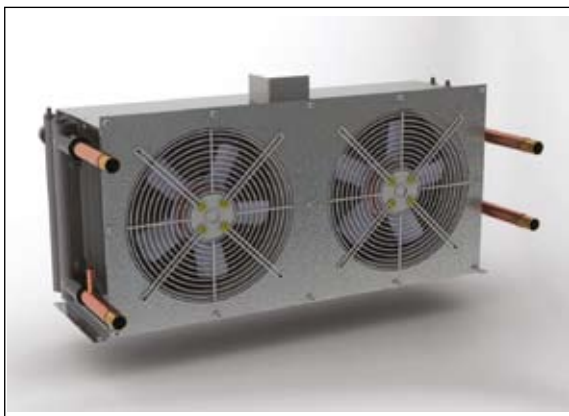

### Standard equipment

- ✓ Colour: RAL 6031
- ✓ Asynchronous generator short-circuit proof
- ✓ Super soundproof hood 6-parts
- ✓ Cooled exhaust gas routing system in the sound insulating capsule
- ✓ External exhaust gas silencer with high damping
- ✓ External radiator incl. electr. circulating pump and fan 230 V
- ✓ BASIC controlpanel incl. 5 m of control wire
- ✓ Electronic engine management with battery charge
- ✓ Engine management with automatically shut off in case of: low oil pressure, high temperature, loss of water
- ✓ Computer-optimised arrangement of the vibration dampers and integrated stop unit limitation of the rubber-bonded metals 4x inside, 4x outside, 4G in all directions
- ✓ Super muted, extremely smooth
- ✓ Handbook industry-standard, German or English
- ✓ 24 V starting system
- ✓ Start limit temperature -32°C
- ✓ Tropical radiator climate zone A1

### Optionally (liable to surcharge)

- Custom winding 230 V – 50 Hz o. 280 V / 127 V - 60 Hz
- Custom cooling unit possible
- Fan control dependent on temperature
- Full-electronic controlpanel with LCD and auto start system
- external air filter
- key turn ready "tunnel" on mounting base with fuel tank
- Room heating appliance, utilisation of the system warmth to 10 kW
- Colour: according to the arrangement
- Air compressor at auxiliary drive for climate performance to 7 kW
- Oil change interval prolongation – partial-flow filter
- electronic speed control
- One service-side for easy service
- external start socket

Technical changes and mistake reserve.

Based on the constant development and modification of the models cannot be guaranteed that specifications comply with current models.

### POWER GENERATORS FOR EXTREME REQUIREMENTS

extremely quiet / extremely compactly / extremely efficient / extremely robustly



**Diesel power generator CAMINO 15 DS MIL**  
full-encased diesel power generator  
for fixed installation in shelter and vehicles.  
Highly adaptable installation system of applications  
with low place relations, super soundproof



Power Generator Type	Camino 15 DS MIL
	3 ~
<b>Output</b>	
Continuous power	12,5 kW / 15,6 kVA
Continuous current	20 A
<b>Engine</b>	
Enginetype	Lombardini FOCS LDW
Stand-by power	15,7 kW
Speed (RPM)	3.000 rpm
Governor	Mechanic
Number of cylinder	3
Coolant system	Water
Alternator	24 V
Starter	24 V
Battery (not included)	45 Ah - 88 Ah
<b>Engine consumption</b>	
Diesel	272 g / kWh
<b>Generator</b>	
Voltage	400 V / 230 V
Frequency	50 Hz
Power factor	cosφ 1/0,8
Insulation class	F
IP	54
Coolant	Water
<b>Dimensions</b>	
Length	846 mm
Width	589 mm
Height	640 mm
Weight	294 kg
Noise level	54 dB(A) @ 7 meter
<b>Accessories included</b>	
exhaust gas muffler	control panel
cooling unit	

Technical changes and mistake reserve.  
Based on the constant development and modification of the models cannot  
be guaranteed that specifications comply with current models.



## POWER GENERATORS FOR EXTREME REQUIREMENTS

extremely quiet / extremely compactly / extremely efficient / extremely robustly

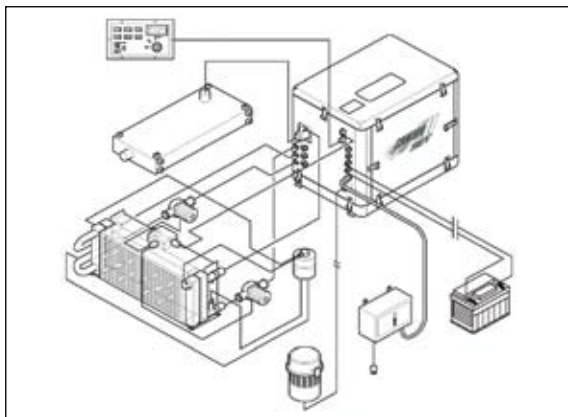

### Standard equipment

- ✓ Colour: RAL 6031
- ✓ Asynchronous generator short-circuit proof
- ✓ Super soundproof hood 6-parts
- ✓ Cooled exhaust gas routing system in the sound insulating capsule
- ✓ External exhaust gas silencer with high damping
- ✓ External radiator incl. electr. circulating pump and fan 230 V
- ✓ BASIC controlpanel incl. 5 m of control wire
- ✓ Electronic engine management with battery charge
- ✓ Engine management with automatically shut off in case of: low oil pressure, high temperature, loss of water
- ✓ Computer-optimised arrangement of the vibration dampers and integrated stop unit limitation of the rubber-bonded metals 6x inside, 6x outside, 4G in all directions
- ✓ Super muted, extremely smooth
- ✓ Handbook industry-standard, German or English
- ✓ 24 V starting system
- ✓ Start limit temperature -32°C
- ✓ Tropical radiator climate zone A1

### Optionally (liable to surcharge)

- Custom winding 230 V – 50 Hz o. 280 V / 127 V - 60 Hz
- Custom cooling unit possible
- Fan control dependent on temperature
- Full-electronic controlpanel with LCD and auto start system
- external air filter
- key turn ready "tunnel" on mounting base with fuel tank
- Room heating appliance, utilisation of the system warmth to 20 kW
- Colour: according to the arrangement
- Air compressor at auxiliary drive for climate performance to 7 kW
- Oil change interval prolongation – partial-flow filter
- electronic speed control
- One service-side for easy service
- external start socket

Technical changes and mistake reserve.

Based on the constant development and modification of the models cannot be guaranteed that specifications comply with current models.

### POWER GENERATORS FOR EXTREME REQUIREMENTS

extremely quiet / extremely compactly / extremely efficient / extremely robustly



**Diesel power generator CAMINO 20 DS MIL**  
 full-encased diesel power generator  
 for fixed installation in shelters and vehicles.  
 Highly adaptable installation system of applications  
 with low place relations, super soundproof

Power Generator Type	Camino 20 DS MIL
	3 ~
<b>Output</b>	
Continuous power	16 kW / 20 kVA
Continuous current	26 A
<b>Engine</b>	
Enginetype	Lombardini FOCSLDW
Stand-by power	21 kW
Speed (RPM)	3.000 rpm
Governor	Mechanic
Number of cylinder	4
Coolant system	Water
Alternator	24 V
Starter	24 V
Battery (not included)	45Ah - 88 Ah
<b>Engine consumption</b>	
Diesel	290 g / kWh
<b>Generator</b>	
Voltage	400 V / 230 V
Frequency	50 Hz
Power factor	cosφ 1/0,8
Insulation class	F
IP	54
Coolant	Water
<b>Dimensions</b>	
Length	929 mm
Width	589 mm
Height	640 mm
Weight	326 kg
Noise level	54 dB(A) @ 7 meter
<b>Accessories included</b>	
exhaust gas muffler	control panel
cooling unit	



Technical changes and mistake reserve.  
 Based on the constant development and modification of the models cannot  
 be guaranteed that specifications comply with current models.



## POWER GENERATORS FOR EXTREME REQUIREMENTS

extremely quiet / extremely compactly / extremely efficient / extremely robustly

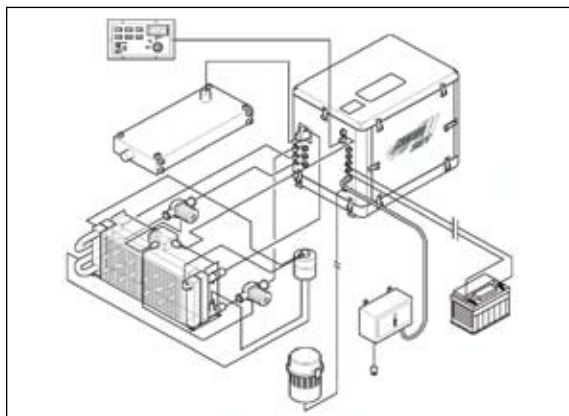

### Standard equipment

- ✓ Colour: RAL 6031
- ✓ Asynchronous generator short-circuit proof
- ✓ Super soundproof hood 6-parts
- ✓ Cooled exhaust gas routing system in the sound insulating capsule
- ✓ External exhaust gas silencer with high damping
- ✓ External radiator incl. electr. circulating pump and fan 230 V
- ✓ BASIC controlpanel incl. 5 m of control wire
- ✓ Electronic engine management with battery charge
- ✓ Engine management with automatically shut off in case of: low oil pressure, high temperature, loss of water
- ✓ Computer-optimised arrangement of the vibration dampers and integrated stop unit limitation of the rubber-bonded metals 6x inside, 6x outside, 4G in all directions
- ✓ Super muted, extremely smooth
- ✓ Handbook industry-standard, German or English
- ✓ 24 V starting system
- ✓ Start limit temperature -32°C
- ✓ Tropical radiator climate zone A1

### Optionally (liable to surcharge)

- Custom winding 230 V – 50 Hz o. 280 V / 127 V - 60 Hz
- Custom cooling unit possible
- Fan control dependent on temperature
- Full-electronic controlpanel with LCD and auto start system
- external air filter
- key turn ready "tunnel" on mounting base with fuel tank
- Room heating appliance, utilisation of the system warmth to 20 kW
- Colour: according to the arrangement
- Air compressor at auxiliary drive for climate performance to 12 kW
- Oil change interval prolongation – partial-flow filter
- electronic speed control
- One service-side for easy service
- external start socket

Technical changes and mistake reserve.  
Based on the constant development and modification of the models cannot be guaranteed that specifications comply with current models.

### POWER GENERATORS FOR EXTREME REQUIREMENTS

extremely quiet / extremely compactly / extremely efficient / extremely robustly



**Diesel power generator CAMINO 30 DS MIL**  
 full-encased diesel power generator  
 for fixed installation in shelters and vehicles.  
 Highly adaptable installation system of applications  
 with low place relations, super soundproof

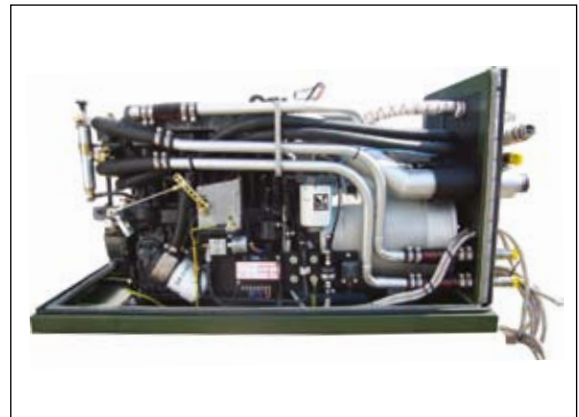

Power Generator Type	Camino 30 DS MIL
	3 ~
<b>Output</b>	
Continuous power	21 kW / 25 kVA
Continuous current	34 A
<b>Engine</b>	
Enginetype	LISTER Petter LPW4
Stand-by power	29 kW
Speed (RPM)	3.000 rpm
Governor	Mechanic
Number of cylinder	4
Coolant system	Water
Alternator	24 V
Starter	24 V
Battery (not included)	88 Ah
<b>Engine consumption</b>	
Diesel	295 g / kWh
<b>Generator</b>	
Voltage	400 V / 230 V
Frequency	50 Hz
Power factor	cosφ 1/0,8
Insulation class	F
IP	54
Coolant	Water
<b>Dimensions</b>	
Length	1050 mm
Width	595 mm
Height	690 mm
Weight	395 kg
Noise level	54 dB(A) @ 7 meter
<b>Accessories included</b>	
exhaust gas muffler	control panel
cooling unit	



Technical changes and mistake reserve.  
 Based on the constant development and modification of the models cannot  
 be guaranteed that specifications comply with current models.



## POWER GENERATORS FOR EXTREME REQUIREMENTS

extremely quiet / extremely compactly / extremely efficient / extremely robustly

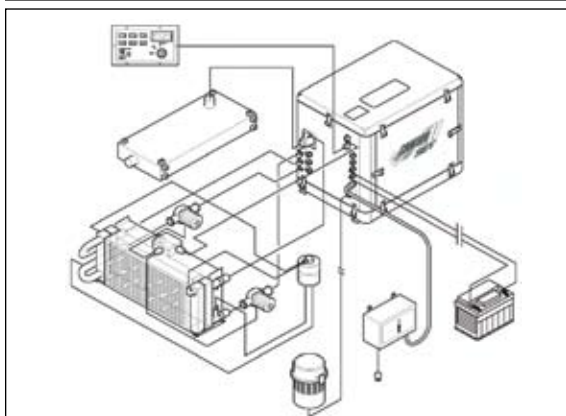

### Standard equipment

- ✓ Colour: RAL 6031
- ✓ Asynchronous generator short-circuit proof
- ✓ Super soundproof hood 6-parts
- ✓ Cooled exhaust gas routing system in the sound insulating capsule
- ✓ External exhaust gas silencer with high damping
- ✓ External radiator incl. electr. circulating pump and fan 230 V
- ✓ BASIC controlpanel incl. 5 m of control wire
- ✓ Electronic engine management with battery charge
- ✓ Engine management with automatically shut off in case of: low oil pressure, high temperature, loss of water
- ✓ Computer-optimised arrangement of the vibration dampers and integrated stop unit limitation of the rubber-bonded metals 6x inside, 6x outside, 4G in all directions
- ✓ Super muted, extremely smooth
- ✓ Handbook industry-standard, German or English
- ✓ 24 V starting system
- ✓ Start limit temperature -32°C
- ✓ Tropical radiator climate zone A1

### Optionally (liable to surcharge)

- Custom winding 230 V – 50 Hz o. 280 V / 127 V - 60 Hz
- Custom cooling unit possible
- Fan control dependent on temperature
- Full-electronic controlpanel with LCD and auto start system
- external air filter
- key turn ready "tunnel" on mounting base with fuel tank
- Room heating appliance, utilisation of the system warmth to 20 kW
- Colour: according to the arrangement
- Air compressor at auxiliary drive for climate performance to 12 kW
- Oil change interval prolongation – partial-flow filter
- electronic speed control
- One service-side for easy service
- external start socket

Technical changes and mistake reserve.  
Based on the constant development and modification of the models cannot be guaranteed that specifications comply with current models.

### POWER GENERATORS FOR EXTREME REQUIREMENTS

extremely quiet / extremely compactly / extremely efficient / extremely robustly



**Diesel power generator CAMINO 35 DS MIL**  
 full-encased diesel power generator  
 for fixed installation in shelters and vehicles.  
 Highly adaptable installation system of applications  
 with low place relations, super soundproof

Power Generator Type	Camino 35 DS MIL
	3 ~
<b>Output</b>	
Continuous power	30 kW / 36 kVA
Continuous current	45 A
<b>Engine</b>	
Enginetype	Deutz F4M2009
Stand-by power	36 kW
Speed (RPM)	3.000 rpm
Governor	Mechanic
Number of cylinder	4
Coolant system	Water
Alternator	24 V
Starter	24 V
Battery (not included)	88 Ah
<b>Engine consumption</b>	
Diesel	280 g / kWh
<b>Generator</b>	
Voltage	400 V / 230 V
Frequency	50 Hz
Power factor	cosφ 1/0,8
Insulation class	F
IP	54
Coolant	Water
<b>Dimensions</b>	
Length	1140 mm
Width	665 mm
Height	690 mm
Weight	550 kg
Noise level	56 dB(A) @ 7 meter
<b>Accessories included</b>	
exhaust gas muffler	control panel
cooling unit	



Technical changes and mistake reserve.  
 Based on the constant development and modification of the models cannot  
 be guaranteed that specifications comply with current models.



## POWER GENERATORS FOR EXTREME REQUIREMENTS

extremely quiet / extremely compactly / extremely efficient / extremely robustly

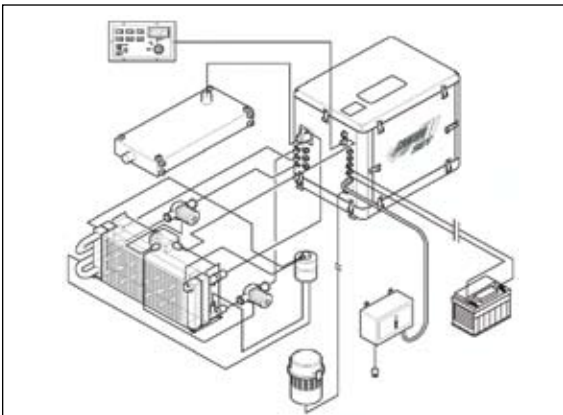

### Standard equipment

- ✓ Colour: RAL 6031
- ✓ Asynchronous generator short-circuit proof
- ✓ Super soundproof hood 6-parts
- ✓ Cooled exhaust gas routing system in the sound insulating capsule
- ✓ External exhaust gas silencer with high damping
- ✓ External radiator incl. electr. circulating pump and fan 230 V
- ✓ BASIC controlpanel incl. 5 m of control wire
- ✓ Electronic engine management with battery charge
- ✓ Engine management with automatically shut off in case of: low oil pressure, high temperature, loss of water
- ✓ Computer-optimised arrangement of the vibration dampers and integrated stop unit limitation of the rubber-bonded metals 6x inside, 6x outside, 4G in all directions
- ✓ Super muted, extremely smooth
- ✓ Handbook industry-standard, German or English
- ✓ 24 V starting system
- ✓ Start limit temperature -32°C
- ✓ Tropical radiator climate zone A1

### Optionally (liable to surcharge)

- Custom winding 230 V – 50 Hz o. 280 V / 127 V - 60 Hz
- Custom cooling unit possible
- Fan control dependent on temperature
- Full-electronic controlpanel with LCD and auto start system
- external air filter
- key turn ready "tunnel" on mounting base with fuel tank
- Room heating appliance, utilisation of the system warmth to 20 kW
- Colour: according to the arrangement
- Air compressor at auxiliary drive for climate performance to 20 kW
- Oil change interval prolongation – partial-flow filter
- electronic speed control
- One service-side for easy service
- external start socket

Technical changes and mistake reserve.

Based on the constant development and modification of the models cannot be guaranteed that specifications comply with current models.

### POWER GENERATORS FOR EXTREME REQUIREMENTS

extremely quiet / extremely compactly / extremely efficient / extremely robustly



**Diesel power generator CAMINO 40 DS MIL**  
 full-encased diesel power generator  
 for fixed installation in shelters and vehicles.  
 Highly adaptable installation system of applications  
 with low place relations, super soundproof

Power Generator Type	Camino 40 DS MIL
	3 ~
<b>Output</b>	
Continuous power	36 kW / 45 kVA
Continuous current	60 A
<b>Engine</b>	
Enginetype	Deutz F4M2011
Stand-by power	43,8 kW
Speed (RPM)	3.000 rpm
Governor	Electronic
Number of cylinder	4
Coolant system	oil
Alternator	24 V
Starter	24 V
Battery (not included)	120 Ah
<b>Engine consumption</b>	
Diesel	235 g / kWh
<b>Generator</b>	
Voltage	400 V / 230 V
Frequency	50 Hz
Power factor	cosφ 1/0,8
Insulation class	F
IP	54
Coolant	Water
<b>Dimensions</b>	
Length	1320 mm
Width	710 mm
Height	780 mm
Weight	860 kg
Noise level	63 dB(A) @ 7 meter
<b>Accessories included</b>	
exhaust gas muffler	control panel
cooling unit	



Technical changes and mistake reserve.  
 Based on the constant development and modification of the models cannot  
 be guaranteed that specifications comply with current models.

## POWER GENERATORS FOR EXTREME REQUIREMENTS

extremely quiet / extremely compactly / extremely efficient / extremely robustly

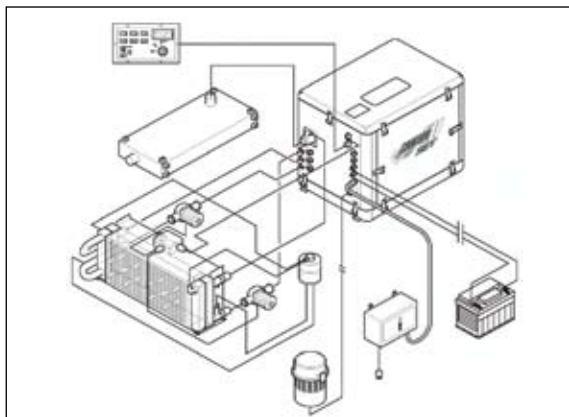
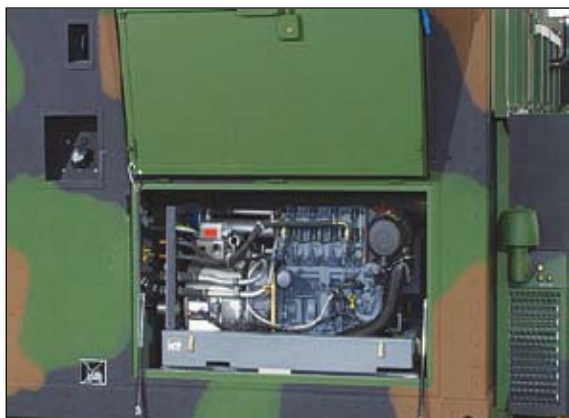

### Standard equipment

- ✓ Colour: RAL 6031
- ✓ Asynchronous generator short-circuit proof
- ✓ Super soundproof hood 6-parts
- ✓ Cooled exhaust gas routing system in the sound insulating capsule
- ✓ External exhaust gas silencer with high damping
- ✓ External radiator incl. electr. circulating pump and fan 230 V
- ✓ BASIC controlpanel incl. 5 m of control wire
- ✓ Electronic engine management with battery charge
- ✓ Engine management with automatically shut off in case of: low oil pressure, high temperature, loss of water
- ✓ Computer-optimised arrangement of the vibration dampers and integrated stop unit limitation of the rubber-bonded metals 6x inside, 6x outside, 4G in all directions
- ✓ Super muted, extremely smooth
- ✓ Handbook industry-standard, German or English
- ✓ 24 V starting system
- ✓ Start limit temperature -32°C
- ✓ Tropical radiator climate zone A1

### Optionally (liable to surcharge)

- Fan control dependent on temperature
- Full-electronic controlpanel with LCD and auto start system
- external air filter
- key turn ready "tunnel" on mounting base with fuel tank
- Room heating appliance, utilisation of the system warmth to 20 kW
- Colour: according to the arrangement
- Air compressor at auxiliary drive for climate performance to 20 kW
- Oil change interval prolongation
- One service-side for easy service
- external start socket

Technical changes and mistake reserve.  
Based on the constant development and modification of the models cannot be guaranteed that specifications comply with current models.

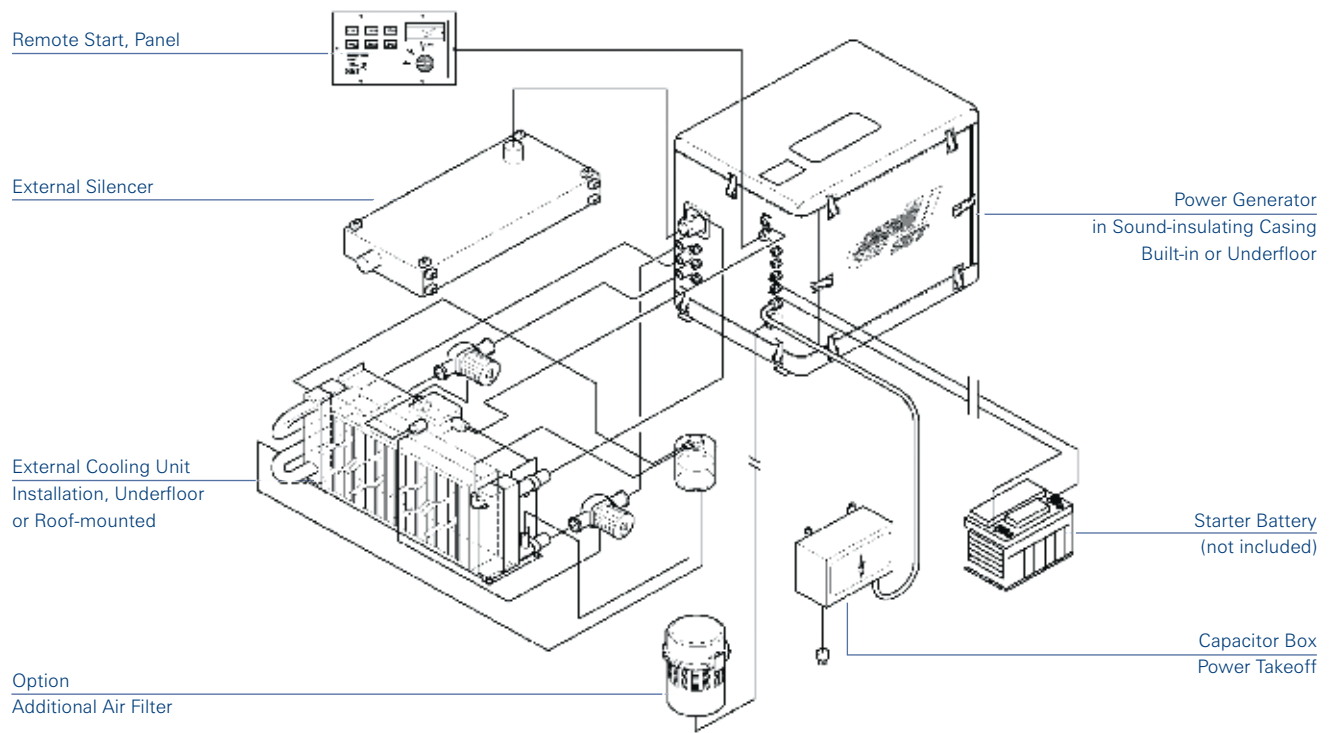

MADE IN GERMANY

SILENT POWER FROM ULTRA-COMPACT  
DIESEL POWER PLANTS



SET Stange Energietechnik GmbH

Lise-Meitner-Straße 15  
40764 Langenfeld  
Fon: +49 (0) 2173/39937-0  
Fax: +49 (0) 2173/39937-20  
E-Mail: [info@set-zeise.de](mailto:info@set-zeise.de)  
Internet: [www.set-zeise.de](http://www.set-zeise.de)