

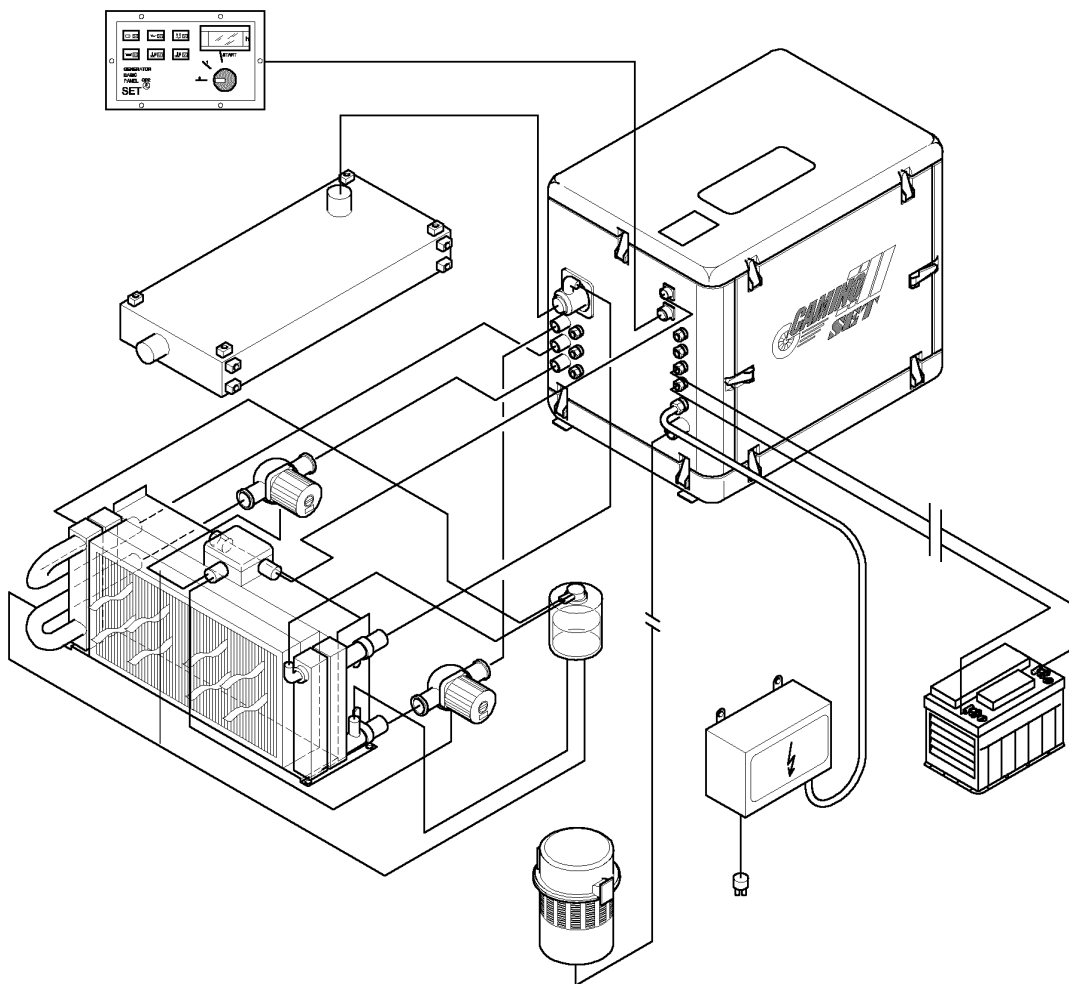

# Installation and start-up manual

## SET Camino Generator Type: 8



**Stange Energietechnik GmbH**

Lise Meitner Str. 15

D-40764 Langenfeld

Tel.: +49 (0)2173 / 399 37-0 • Fax: - / 399 37-20

e-mail: [Info@set-zeise.de](mailto:Info@set-zeise.de) • [www.set-zeise.de](http://www.set-zeise.de)

## Preface

**SET-CAMINO Generator** for safe and mains-independent power supply.

The **SET-CAMINO Generator** is designed for installation in vehicles.

It is particularly suited due to:

- Its ideal **construction, workmanship** and **function**.
- High **safety in operation** and nearly unlimited **service life**.
- Low **power consumption**.
- Compact **installation dimensions**.
- Excellent **sound insulation**.

**Mains-independent power supply powerful, small and low-noise** only by Stange Energietechnik GmbH with original **SET-CAMINO Generators**.

.

Have installation and mounting carried out only by a specialised workshop authorised by **SET**.

Please do not hesitate to contact us for mounting, planning and installing the **SET-CAMINO Generator**:

### **Stange Energietechnik GmbH**

Lise Meitner Str. 15  
D-40764 Langenfeld

Tel.: +49 (0)2173 / 399 37-0  
Fax: +49 (0)2173 / 399 37-20  
e-mail: [Info@set-zeise.de](mailto:Info@set-zeise.de)  
[www.set-zeise.de](http://www.set-zeise.de)

**Table of contents**

<b>1</b>	<b>Introduction.....</b>	<b>1-5</b>
<b>2</b>	<b>Basic safety notes .....</b>	<b>2-6</b>
2.1	Safety provisions.....	2-6
2.1.1	Obligations of the owner .....	2-6
2.1.2	Pictograms for safety and danger hints.....	2-7
2.1.3	Principle; application for the purpose intended.....	2-7
2.2	Organisational measures.....	2-8
2.3	Basic duties.....	2-9
2.4	Safety hints for certain operating phases .....	2-9
2.4.1	Normal operation.....	2-9
2.4.2	Continuous operation .....	2-10
2.4.3	Special work.....	2-10
2.5	Hints for specific types of danger.....	2-11
2.5.1	Electrical power.....	2-11
2.5.2	Gas, dust, steam, smoke .....	2-11
2.6	Notes for warranty and liability.....	2-12
2.6.1	Storing the generator .....	2-12
2.6.2	Claims .....	2-12
2.6.3	Figures and drawings.....	2-12
2.6.4	Protected rights.....	2-12
2.6.5	Environmental protection .....	2-13
2.6.6	Dangers and warning signs.....	2-13
<b>3</b>	<b>Preparation for installation .....</b>	<b>3-14</b>
3.1	Scope of supplies.....	3-14
3.2	Protective measures against mechanical risks.....	3-15
3.3	Protective measures against electrical risks.....	3-15
3.3.1	Electrical risks in the AC circuit 230V 50Hz.....	3-15
3.3.2	Electrical risks in the DC circuit 12V.....	3-15
3.4	Protective measures for the electrical installation .....	3-16
3.4.1	Electrical installation of the AC circuit 230V 50Hz.....	3-16
3.4.2	Electrical installation of the DC circuit 12V .....	3-17
3.5	Protective measures for mechanical installation .....	3-17
3.6	Fuel system.....	3-18
3.7	Combustion air supply .....	3-18
3.8	Safety notes, summary .....	3-19
3.9	Exhaust gas system.....	3-20
3.10	Cooler unit.....	3-20
<b>4</b>	<b>Installation data .....</b>	<b>4-21</b>
4.1	Technical data.....	4-21
4.1.1	Technical data „SET Camino Generator“ .....	4-21
4.1.2	Technical data „drive engine“ .....	4-22
4.2	Technical installation data .....	4-23
4.2.1	Dimensions – „soundproofing hood“ .....	4-23

4.2.2	Dimensions „mounting frame“ .....	4-24
4.3	Dimensions „cooler unit example“ .....	4-25
4.4	Connections and links at the SET Camino Generator .....	4-26
4.4.1	Electrical and control connections .....	4-26
4.4.2	Cooling system connections .....	4-27
4.4.3	Fuel supply connections .....	4-28
4.4.4	Exhaust gas system connections .....	4-29
4.4.5	External air filter connection (Option)* .....	4-30
<b>5</b>	<b>Installation of the SET Camino Generator .....</b>	<b>5-31</b>
5.1	General .....	5-31
5.2	Environment .....	5-32
5.3	Foundation .....	5-33
5.4	Installation of the cooling system .....	5-34
5.4.1	Direction of delivery of the coolant .....	5-35
5.4.2	Piping at the cooling circuit „generator“ .....	5-36
5.4.3	Piping at the cooling circuit „engine“ .....	5-37
5.4.4	Piping „expansion vessel“ .....	5-38
5.5	Installation of external air filter (Option) .....	5-39
5.6	Installation of the exhaust gas system .....	5-40
5.7	Installation of the fuel system .....	5-41
5.7.1	Installation of the separate fuel supply system .....	5-42
<b>6</b>	<b>Electrical installation .....</b>	<b>6-44</b>
6.1	Installation of control panel .....	6-45
	Connection of the electrical fuel delivery pump .....	6-47
6.2	Connection of main capacitor and main distributor .....	6-48
6.3	Electrical system of the vehicle .....	6-49
6.4	Connection for additional 12 V consumer .....	6-50
6.5	Mounting and installation of the starter battery .....	6-51
<b>7</b>	<b>Initial start-up .....</b>	<b>7-53</b>
7.1	Coolant filling .....	7-54
7.2	Operation .....	7-55
7.3	Start-up .....	7-55
7.3.1	For initial start proceed as follows .....	7-57
<b>8</b>	<b>Installation documents of sub-suppliers .....</b>	<b>8-58</b>
8.1	Sub-supplier documents - General .....	8-58
8.2	Sub-supplier documents - Engine .....	8-58
8.3	Sub-supplier documents - Generator .....	8-58
8.4	Sub-supplier documents – Electrical/control system .....	8-58
8.5	Sub-supplier documents – Cooling system .....	8-58
8.6	Sub-supplier documents – Tank system* .....	8-58
8.7	Sub-supplier documents – External air filter* .....	8-58
8.8	Sub-supplier documents – Exhaust gas system .....	8-58

## 1 Introduction

Prior to installing, connecting and/or starting, please read this manual which has been specifically prepared for the **SET-CAMINO Generator**.

Installation can be carefully prepared only when you are acquainted with the installation and start-up manual. Only in this way it is possible to procure installation accessories and the desired options in due time.

This **Installation and start-up manual** includes chapters covering the following subjects:

- Basic safety notes
- Installation preparation and installation data
- Installation of the **SET Camino Generator**
- Electrical installation
- Initial start-up
- Installation documents of sub-suppliers

The separate Operating **manual** with the following chapters should be used by the operator of the **SET-CAMINO Generator**...

- How to handle the **SET Camino Generator**
- Construction and functioning
- Activation and operation
- Preventive and corrective maintenance
- Elimination of failures and faults
- Operating and maintenance manuals of sub-suppliers

Thus please read the operating manual and the installation/start-up manual carefully prior to any manipulation. It contains important information, regulations and safety rules.

## **2 Basic safety notes**

### **2.1 Safety provisions**

No warranty and liability claims will be accepted for personal and property damage if due to one or several of the following causes:

- Non-compliance with these particular or other known precautions.
- Failure to operate and handle the unit with the necessary care.

#### **2.1.1 Obligations of the owner**

The owner shall agree to start up the generator only after having made himself acquainted with the safety regulations and handling of the generator.

These are:

- Accident prevention regulations
- General and engine/plant related safety notes
- Safeguards of the generator
- Actions in emergency cases
- Operation of the generator
- Activities when starting up the generator
- Behaviour in case of failure
- Shutting down the generator
- Transport of the generator
- Disposal of utilities and auxiliary materials

The generator shall be installed properly by specialists only.

1. Check the place of installation and its environment for suitability.
2. You are obliged to eliminate any danger at the generator and its operation.
3. The operating manual must be readily available for the operator at the place of installation of the generator.
4. Follow the regulations for safe working and accident prevention.
5. The operating manual must have been read and understood.
6. Follow the actions dealt with in the operating manual.
7. Pictograms in the operating manual are used to underline particularly important information (for explanations of the pictograms refer to chapter 2.1.2).

8. The unit shall be operated only with the soundproofing housing closed.
9. With the soundproofing housing open, there is the risk of injury by the belts of the dynamo.
10. The electrical loading of the generator by connected power consumers must not exceed that indicated at the nameplate.

### 2.1.2 Pictograms for safety and danger hints

The following pictograms indicate where safety and danger hints in this operating manual must be complied with in particular:



***Emphasises dangerous situations with possible personal injury, also possible generator damage.***



***Danger due to electrical current. The necessary works shall be carried out only by specialised electricians.***



***Notes concerning useful hints, explanations and supplements for handling the generator.***



***No Smoking***



***Fires and open light forbade.***

### 2.1.3 Principle; application for the purpose intended

The generator has been built in accordance with the latest state of the art and approved safety rules. The requirements of the generator applicable in the manufacturer's country, Germany, (DIN, VDE and Machine Protection Act) have been taken into account. However, improper use may cause danger to the life and limb of the user or third parties as well as damage to the generator and other property.

Use the generator only in proper technical condition and for the purpose intended as well as according to safety standards with due consideration given to potential hazards! Eliminate any failure immediately which might affect safety (or have them eliminated).

The SET-CAMINO generator shall be used only for power generation and operating electrical units with coincident voltages.



***Application for the purpose intended also includes compliance with the operating manuals and meeting the inspection and maintenance requirements.***

## 2.2 Organisational measures

Keep the operating manual easily accessible at the place of installation of the generator (in tool compartment or the box provided for this purpose)!

In addition to the operating manual, follow and direct the general legal and other binding regulations for accident prevention and environmental protection! Such duties may also refer, for instance, to the handling of dangerous materials or the provision/wearing of personal protective equipment.

The operating manual must have been read and understood.

It will be too late during service. This is particularly applicable to persons who work time and again only at the generator, e.g. during setting up, maintenance, etc.

Use the personal protective equipment if necessary or required by regulations!

Observe all safety and danger notes at the generator!

Keep all safety and danger notes at the generator in readable state!

Shut down the generator immediately in case of safety relevant modifications at the generator or its operating performance. Do not carry out any modification and/or attachments or re-structuring work at the generator unless the prior written approval by the manufacturer has been obtained. This might affect the safety of the generator! This is also applicable to the installation and setting of safeguards and safety valves as well as for welding work carried out at load-bearing components. Any structural modification shall be done by the manufacturer only.

Use only original spare parts and original accessories of the manufacturer! Spare parts and accessories must meet the technical requirements specified by the manufacturer. Original components will ensure this.

Replace all hose lines at the intervals indicated and/or appropriate, even if no safety relevant defects can be seen!

Keep the intervals for repeated checks/inspection which are specified or given in the operating manual!

Appropriate workshop equipment is required to carry out maintenance/repair work.

Inform yourself of special tools!

Observe the fire alarm and fire fighting facilities!

Inform other persons of the location and operation of fire extinguishers!

## **2.3 Basic duties**

Work at/by the generator shall be carried out only by reliable personnel. Observe the legally admissible minimum age!

Work at the electrical equipment of the generator shall be carried out only by specialised electricians in accordance with the rules of electrical engineering. Work at electrical supply installations shall be carried out by authorised specialists only in compliance with the DIN VDE provisions and the regulations of the relevant country. Check the electrical design of the generator at regular intervals.

## **2.4 Safety hints for certain operating phases**

Follow the specific safety notes during the individual phases of operation.

### **2.4.1 Normal operation**

Refrain from any activity which might affect safety!

Arrange for the necessary precautions so that the generator is operated only in safe and properly functioning state!

Operate the generator only with all safeguards and safety devices, e.g. removable safeguards, emergency OFF devices, sound insulation, exhaustion systems, mounted and functioning properly!

Check the generator for visible damage and defects once a day! Eliminate changes, if any (including the operating performance) immediately, shut down and secure the generator, if necessary!

In case of functional failures, shut down and secure the generator immediately! Eliminate failure immediately (or have them eliminated)!

Observe the switching on/off processes, control display in accordance with the operating manual!

Prior to switching on/starting the generator, make sure that no person is at risk due to the starting generator!

Do not switch off and/or remove exhaustions and bleeding units with the generator running.

### 2.4.2 Continuous operation

Note and follow the national working, operating and safety regulations for safely handling this generator and its trouble-free operation.

Check the generator for visible damage at regular intervals!

The generator and the control system shall be operated only by instructed operators!

The parameters set by the manufacturer are standard setting values!

Follow all hints given for the case of malfunction (refer also to the chapter „Failure, elimination of failure, repair“). If the actions mentioned there do not result in the elimination of failure, please contact the SET after-sales service department!

Tel.: +49 (0)2173 / 399 37-0 • Fax: - / 399 37-21

e-mail: [service@set-zeise.de](mailto:service@set-zeise.de) • [www.set-zeise.de](http://www.set-zeise.de)

### 2.4.3 Special work

- Carry out all maintenance and installation work at the generator according to the hints. Shut down the generator properly.
- Any person in the facility of the owner who is authorised to carry out assembly, start-up, operation, maintenance, repair or other work, shall have read and understood the operating manual, and in particular the safety notes.
- Keep all setting, maintenance and inspection work and dates specified in the operating manual, including the data concerning the replacement of components/sub-assemblies! This work shall be carried out only by specialised personnel.
- Observe all switching on/off processes according to the operating manual and the hints for maintenance for any work related to the operation, production adaptation, re-equipment or setting of the generator and its safety relevant equipment as well as inspection, maintenance and repair!
- Switch off and secure the generator against unintended re-connection when carrying out maintenance work!
- Lock the main command facilities, withdraw the key and keep it!
- Attach a warning plate at the main switch!

## 2.5 Hints for specific types of danger

### 2.5.1 Electrical power

- Use only original fuses with the amperage specified! Switch off the generator immediately in case of power failure!
- Work at electrical installations or operating means shall be carried out only by specialised electricians in accordance with the rules of electrical engineering.
- Disconnect all engine and plant parts at which inspection, maintenance or repair work shall be carried out, from the voltage supply. Check the disconnected components for their proper isolation prior to start any work!
- Check/inspect the electrical equipment of the generator at regular intervals. Eliminate defects, such as loose connections and/or burnt cables immediately.
- If work shall be carried out at live components, employ a second person who can activate the emergency off and/or main switch with voltage release in case of emergency. Use voltage-insulated tools only!

For work at high-voltage sub-assemblies, connect the supply cable to ground and short-circuit the components, e.g. capacitors, with the earthing rod after having disconnected the voltage!

Check the electrical design of the generator at regular intervals.

### 2.5.2 Gas, dust, steam, smoke

- Carry out welding, burning and grinding work at the generator only after having obtained the specific permission. There may be fire and explosion danger!
- Prior to carry out welding, burning and grinding work, clean the generator and its environment from dust and inflammable materials and arrange for sufficient ventilation (danger of explosion)!
- Observe the national regulations, if any, for work in narrow spaces!
- Follow the safety regulations applicable to the product when handling oils, greases and other chemical substances!
- Be careful when handling hot utilities and auxiliary materials (danger of burns and/or scalding)!

## 2.6 Notes for warranty and liability

- Have repair and maintenance work carried out by a specialised workshop approved by **SET**.
- **SET** will not accept responsibility and liability for work carried out by third party's personnel.
- The „General Terms and Conditions of Sale and Supply“ of **SET** shall be applicable in any case. They will be provided to the owner when signing the contract at the latest.

Warranty and liability claims for personal and property damage shall be excluded if due to one or several of the following causes:

- Use of the generator for purposes other than the intended.
- Improper assembly, start-up, operation and maintenance of the generator.
- Operating the generator with defects.
- Non-compliance with the notes in the operating manual concerning transport, storage, assembly, start-up and maintenance.
- Unauthorised structural modification to the generator.
- Poor monitoring plant components which are subject to wear.
- Improperly carried out repair work, use of third party's components.
- Catastrophes due to the effects of foreign bodies and Force Majeure.

### 2.6.1 Storing the generator

No warranty claims will be accepted by **SET GmbH** for corrosion damage and frost damage due to improper storage, such as moist rooms or the like.

### 2.6.2 Claims

No replacement or warranty claims will be accepted for improper transport. In case of doubt, contact the manufacturer prior to transport.

### 2.6.3 Figures and drawings

Are used for general illustration and shall not be decisive for the construction of individual components. The dimensions specified shall not be binding.

### 2.6.4 Protected rights

Any right in drawings and other documents as well as any disposal right such as copy and disclosure rights shall remain with **SET GmbH**, even in case of the application of protected rights.

### **2.6.5 Environmental protection**

- Dispose used materials and substances according to the applicable regulations.  
Disposal of materials in accordance with environmental standards will promote the re-use of valuable materials.

### **2.6.6 Dangers and warning signs**

The dangerous areas of the generator are identified by warning plates. These signs contain information which will protect you from dangers to health, fatal injuries or property damage!

- Read the appropriate text and follow it during work at any case!
- The danger and warning signs shall be properly recognised and read by the operator!
- Do not remove the plates and signs!

We wish you success and joy with your  
**SET-CAMINO Generator!**

### 3 Preparation for installation

#### 3.1 Scope of supplies

The **SET Camino Generator** has been packed cleanly after the final inspection by our quality assurance department. The generator is transported on a wooden pallet. All components are securely mounted at the pallet. When unpacking, please check the generator for damage due to transport. In case of damage, if any, please inform the forwarding agency immediately.

In detail:

CAMINO generator consisting of:

- Capacitor box
- Cooling unit complete
- Exhaust gas silencer
- Control panel for installation
- Control cable with plug
- Operating manual **SET**
- Engine manual **Kubota**

### **3.2 Protective measures against mechanical risks**

The unit is suspended freely oscillating. Vibration absorbers between the soundproofing housing and the assembly frame as well as inside the soundproofing housing ensure low-vibration operation.

All components required to operate the **SET Camino Generator** are screwed to the unit.

Bushings in the housing of the soundproofing housing allow installation of the supply connection and the outgoing cables without risk.

The sound insulation material used is self-extinguishing in accordance with DIN 752 000.

The generator is designed so that it withstands all loads if used for the purpose intended.

Properly connect the assembly frame with the vehicle body at the points provided for this purpose.

### **3.3 Protective measures against electrical risks**

Electrical safety has top priority and is achieved by various protective measures.

#### **3.3.1 Electrical risks in the AC circuit 230V 50Hz**

Type of protection IP54 of the generator ensures complete protection against contact with live components and against damaging dust deposits and splash water.

Insulation class „F“ of the winding of the generator is characterised by a high temperature and high short-circuit resistance.

The generator is interference suppressed according to VDE 0875 interference level N.

All metal parts of the generator are connected to earth.

#### **3.3.2 Electrical risks in the DC circuit 12V**

The electrical installation of the generator is of the 2-pole type.

Installed fused in the control module (electronic box)

Fuses: 1 x 15 A, 1 x 3 A, 1 x 5 A.

Plug connectors are completely insulated, the plug for the control line is torsionally safe and thus also safe against pole changes.

A sophisticated smart electronic generator Diesel monitoring system protects the generator's system against damage and mal-operation.

### 3.4 Protective measures for the electrical installation



***The electrical system shall be installed by specialised electricians only.***

#### 3.4.1 Electrical installation of the AC circuit 230V 50Hz

The distribution box for electrical power – to be mounted by the customer – shall be at least of IP 54 type of protection.

Install a 2-pole change-over switch with the positions 1 – 0 – 2 as mains/generator switch.

Install miniature circuit breakers per consumer circuit to protect the consumer circuits.

Lead the electronic connection lines through the appropriate screwed conduit entries.



***When replacing a connection line tighten the screwed joints firmly and check for tension.***

- Install a protective conductor when installing the electrical system.
- Direct earthing of the generator with the vehicle body is required here.
- In accordance with the regulations of the manufacturer's country, the protective measure fault current protective circuit (FI residual current circuit breaker) is required.

Residual current circuit breaker: 0.03A

Another protective measure can be prescribed for installations in other countries. The installation company for the plant shall be liable in case of accidents if these regulations are not complied with.

### 3.4.2 Electrical installation of the DC circuit 12V

1. Do not connect the pole terminals to the battery unless the installation is completed, the Diesel engine is ready for operation and the start switch is in OFF position
2. Check pole terminals for tight seat.
3. Apply anti-acid grease to the pole heads and pole terminals.
4. All control lines are switched in a water-proof plug connector.
5. Electrical installation is minimised.
6. A 3 A line fuse is installed in the terminal box for the use of the electrical fuel delivery pump beside the **SET Camino Generator**.
7. The connection cables for the starter battery are lead out of the soundproofing hood, the connection cables are marked (+) and (-) and are provided with pole terminals with the same identification (+) and (-)



***The line cross-section of the connection cables lead out of the sound protected hood is designed for the erection of the starter battery in the immediate vicinity of the generator.***

### 3.5 Protective measures for mechanical installation



***The electrical system shall be installed by a specialised electrician only. No warranty claims will be accepted in case of improper installation.***

### 3.6 Fuel system

If an external Diesel tank is to be installed, use design-approved tanks only. Select a suitably large tank because the fuel is used to cool the nozzles

When using a common Diesel fuel tank with the main engine, install a suitable foot-operated valve and a ball valve at the tank connection.



***All components, pipings and connections must be suitable for Diesel fuel. Install the fuel lines made of fire-resistant tubing with steel thread sheathing according to fire prevention standards.***

Permanently installed lines may also consist of copper pipe.

Under certain circumstances it will be necessary to install a primary fuel filter at the water separator.

The electrical fuel delivery pump used must be suitable for Diesel fuel.

The supply and return lines in the tank must reach the tank bottom.

### 3.7 Combustion air supply

- Combustion air is taken in through the opening in the soundproofing hood directly from the engine room.
- If the temperature of the ambient air in the engine room exceeds 20 °C, supply fresh air from outside.
- Supply fresh air through a 40 mm diameter hose. The length of the hose must not exceed 3 m.
- Mount the external air filter, if required.
- Mount an external air filter\* in case of excessive air pollution.

\* Option (refer to SET range of accessories)

### 3.8 Safety notes, summary

8. Check and maintain the starter battery after a longer interruption of operation.
9. Prior to starting the generator, check all connections for tight seat and proper condition.



***Increased risk of fire due to leaking fuel.***

Malfunction in the system may occur due to failure of the engine cooling or generator cooling system.

- Operate the generator only with the soundproofing hood closed.



***Increased risk of injury due to rotating engine components.***

- The air inlet opening in the soundproofing hood must be open so that the combustion air can flow in easily.
- Carry out maintenance and inspection work in accordance with the specification of this manual.
- Use original and identical **SET** spare parts only for repair work.
- Work at the electrical installation shall be carried out only by specialised electricians with due consideration given to the applicable regulations.
- Do not start the generator without properly functioning cooling water system.



***Fuel must not contact the hot surfaces of the generator. Risk of fire!***



***No Smoking***



***Fires and open light forbade.***

### 3.9 Exhaust gas system

- All components of the exhaust system used must be of heat-resistant material and installed according to fire prevention standards.  
Use original **SET** installation parts only.
- The required dimensions must be kept

### 3.10 Cooler unit

- Suction-proof hose only shall be used.
- The required dimensions must be kept.
- Check the coolant at the expansion vessel at regular intervals.
- The cooling air inlet must have at least the 1.2fold of the area of the cooler.
- The cooling air outlet (free outlet) must have at least the area of the cooler.



***Please ensure to increase the cooler air outlet area when using louvres.***

## 4 Installation data

### 4.1 Technical data

#### 4.1.1 Technical data „SET Camino Generator“

	CAMINO 8
Manufacturer	SET
Output (...kW; cos.phi 1*)	5,5 kW
Voltage (...V ± 6%)	230V
Amperage (single-phase operation)	25 A
Battery charge	14 V - 11 A
Coolant filling (water with anti-freezing agent)	8 l
Cooling water required (for direct cooling)	20 l / min
Type of protection	IP 54
Insulation class	"F"
Frequency	50 Hz +/- 3 %
	CAMINO 8
Manufacturer	SET
Output (...kW; cos.phi 1*)	5,5 kW
Voltage (...V ± 6%)	230V
Amperage (single-phase operation)	12.8 / 35 A
Battery charge	14 V - 20 A
Coolant filling (water with anti-freezing agent)	8 l
Cooling water required (for direct cooling)	20 l /min
Type of protection	IP 54
Insulation class	"F"
Frequency	50 Hz +/- 3%
Sound level ... dB(A)	54

- The full output can be achieved only after a running in phase of approx. 50 hours of operation.
- The short-circuit proof, self-exciting revolving-field generator can be overloaded to 10 % for a short period of time.
- For three-phase generators, load unbalance up to 80 % is possible.

#### 4.1.2 Technical data „drive engine“

	<b>CAMINO 8</b>
Drive engine	Kubota
Cooling (water with anti-freezing agent)	Water
Bore	67 mm
Stroke	68 mm
Displacement	497 cm <sup>3</sup>
Rated speed	3000 min <sup>-1</sup>
Engine output acc. to DIN 6270	9.32 kW
Combustion air required	0.92 m <sup>3</sup> /min
Exhaust gas volume	1.29 m <sup>3</sup> /min
Max. exhaust gas counter-pressure (H <sub>2</sub> O)	1200 mm
Fuel consumption	280 g/kWh
Luboil filling SAE 10 - 40	2,5 litres
Coolant filling (water with anti-freezing agent)	8 litres
Cooling water required (for direct cooling)	20 l/min
Thermostat	80 °C
Max. admissible inclined position of engine	Permanent 25 ° short-time 35 °

- The dynamo supplies 14 V DC to charge the starter battery; load unbalance up to 80 % is possible.

## 4.2 Technical installation data

### 4.2.1 Dimensions – „soundproofing hood“

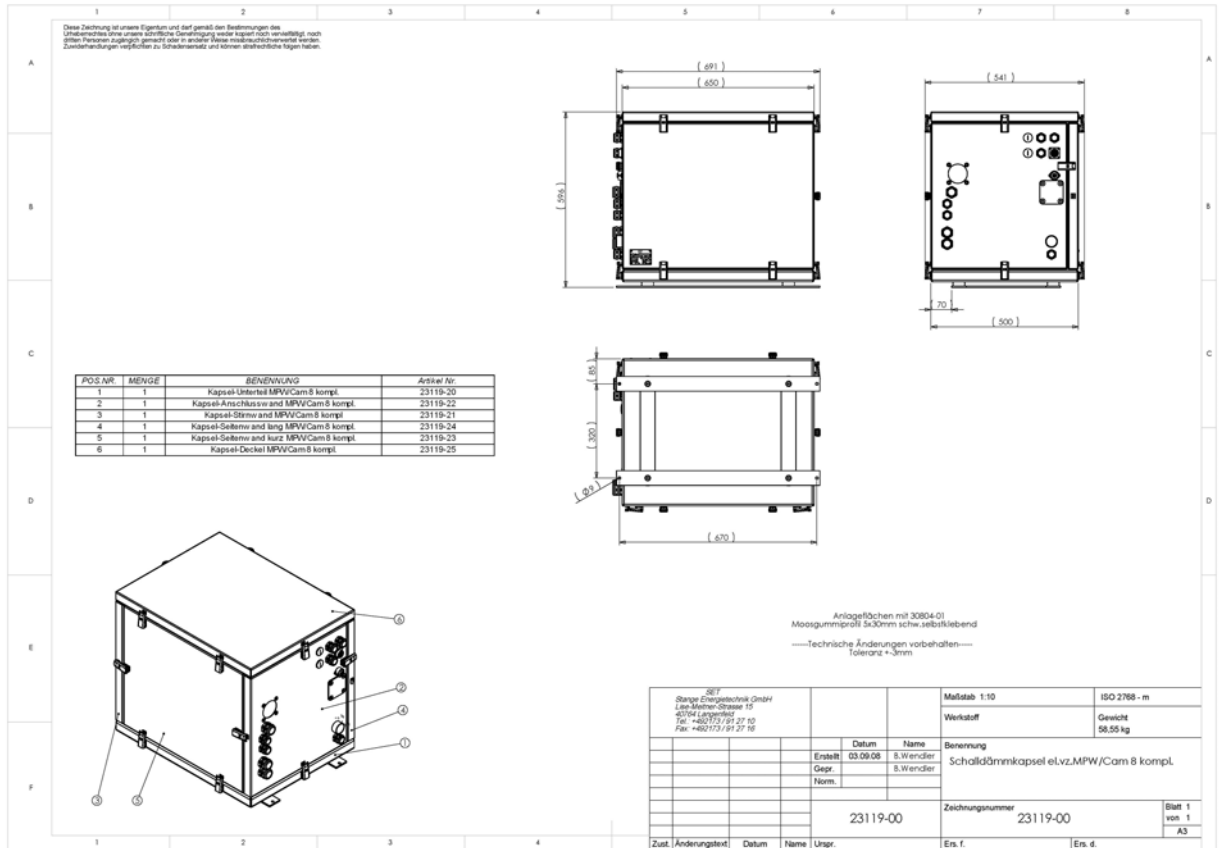

	Designation	CAMINO 8
1.	<b>Output class</b>	<b>5,5 kW</b>
2.	Installation position: (inclination in any direction)	$\pm 25$ degrees
3.	Weight	210 kg
4.	Length (L....mm)	650
5.	Total length incl. connections (....mm)	725
6.	Width (B....mm)	500
7.	Height (H....mm)	593



**Deviations possible!**  
**Please note also the dimensional sheets in the Annex.**

#### 4.2.2 Dimensions „mounting frame“

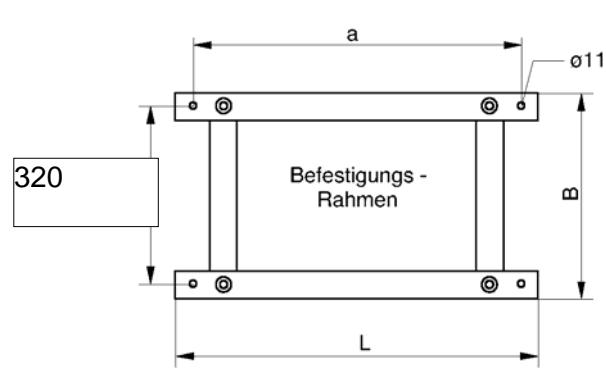

	Designation	CAMINO 10
1.	<b>Output class</b>	<b>5,5 kW</b>
2.	Length (L.....mm)	670
3.	Distance of bores (a.....mm)	650
4.	Width (B.....mm)	370



***Deviations possible!***  
***Please note also the dimensional sheets in the Annex.***

### 4.3 Dimensions „cooler unit example“

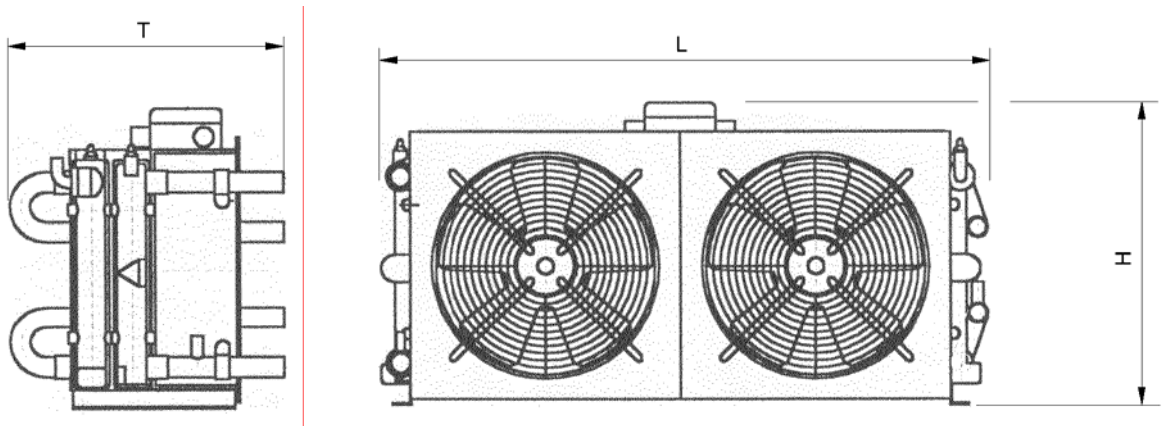

The **SET** cooler unit ..... is described as an example for several possible cooler versions\*. \* (refer also to **SET** range) Other cooler units\* can be delivered depending on the order, conditions and application.

	Designation	CAMINO 8
1.	<b>Output class</b>	<b>5,5 kW</b>
2.	Length (L....mm)	675
3.	Height (H....mm)	383
4.	Depth (T....mm)	230



***Deviations possible!***  
***Please note also the dimensional sheets in the Annex.***

## 4.4 Connections and links at the SET Camino Generator

### 4.4.1 Electrical and control connections

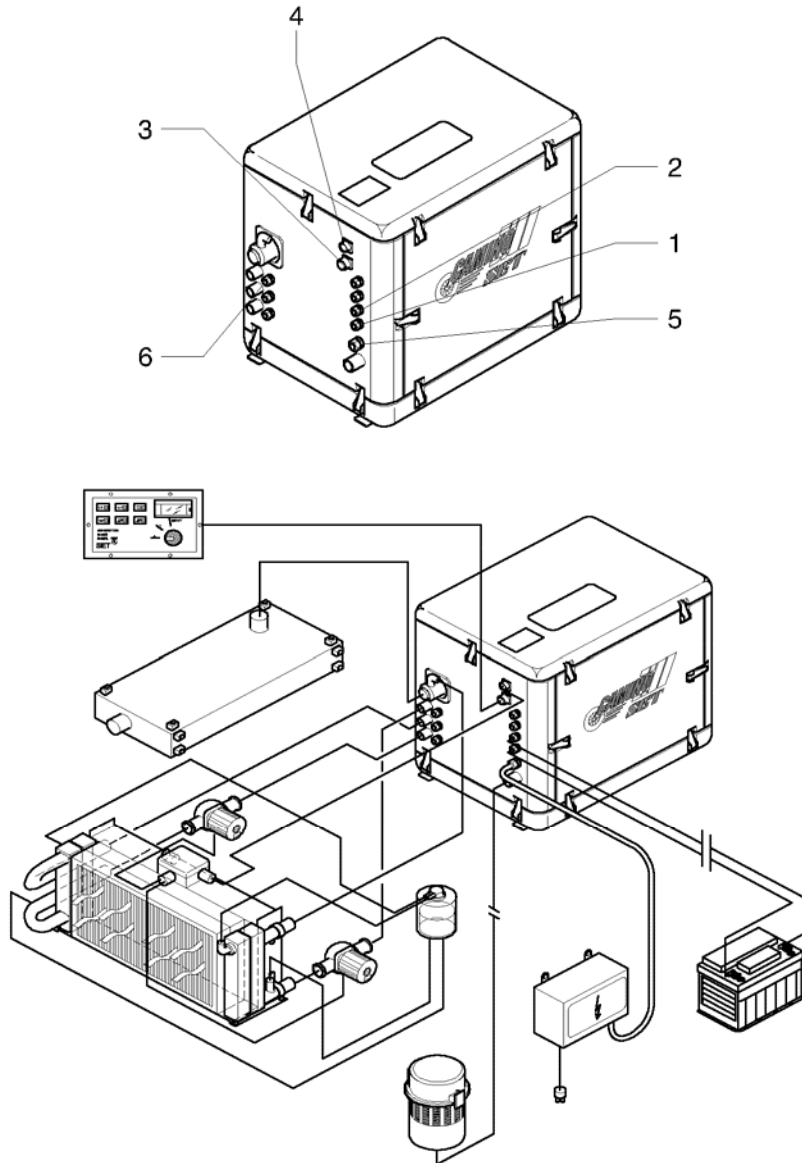

	from	to	Type / size
1.	<b>Engine starter</b>	<b>Starter battery</b>	(+) Pole cable/1.0 m long
2.	<b>Engine ground</b>	<b>Starter battery</b>	(-) Pole cable/0.8 m long
3.	<b>Electronic box</b>	<b>Control panel</b>	Supplied 5 m cable
4.	<b>Electronic box</b>	<b>Cooler control system</b>	Supplied 2 m cable
5.	<b>Generator with fixed capacitor</b>	<b>Residual current circuit-breaker/fuses/external consumers 230V /</b>	<b>Do not disconnect. Danger to life!!</b> Wired at the manufacturer's/supplied 2.0 m power cable
6.	<b>Generator power connection</b>	<b>External consumers 14V/2 x 3A</b>	Supplied 0.5 m cable

#### 4.4.2 Cooling system connections

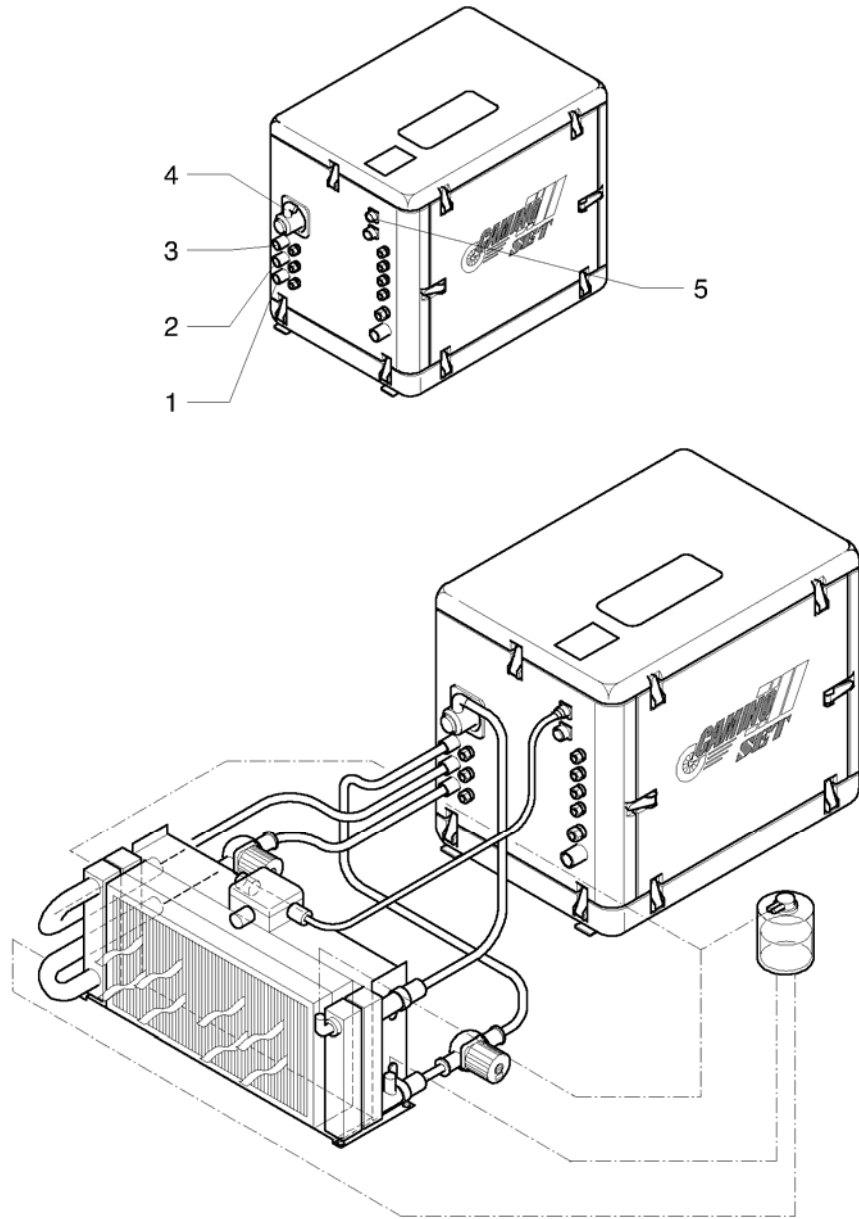

	From	to	Type / size
1.	<b>Engine coolant pump</b>	<b>Cooler (supply line)</b>	Coolant hose Ø 18 x * long
2.	<b>Engine block</b>	<b>Cooler (return line)</b>	Coolant hose Ø 18 x * long
3.	<b>Generator block</b>	<b>Cooler (supply line)</b>	Coolant hose Ø 15 x * long
4.	<b>Generator and cooled ex- haust gas manifold</b>	<b>Cooler (return line)</b>	Coolant hose Ø 15 x * long
5.	<b>Electronic box</b>	<b>Cooler control system</b>	Supplied 2 m cable

\* Length optional

### 4.4.3 Fuel supply connections

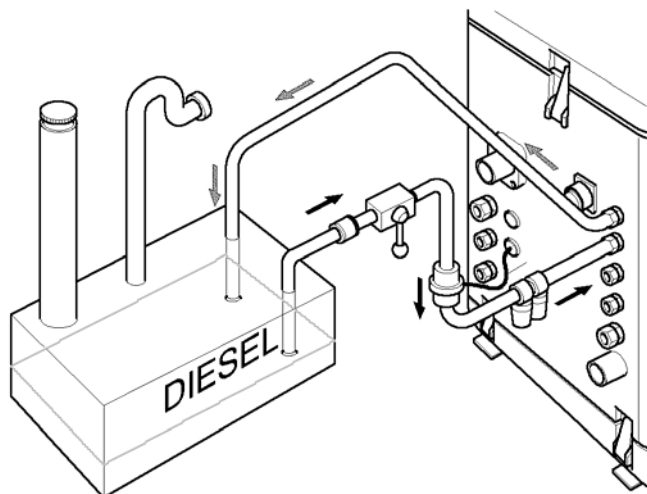
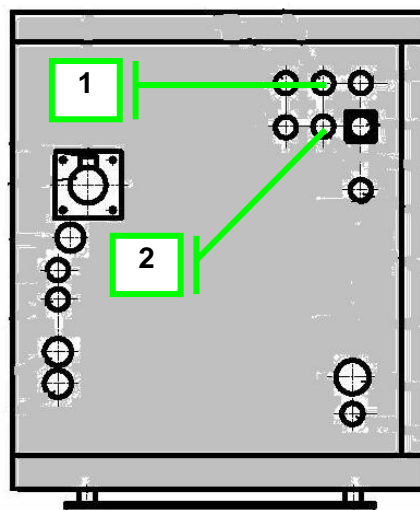

	from	to	Type / size
1.	<b>Engine fuel</b> supply line	<b>Filter / tank</b>	Supply line / 0.2m lg.
2.	<b>Engine fuel</b> return line	<b>Filter / tank</b>	Supply line / 0.2m lg.

#### 4.4.4 Exhaust gas system connections

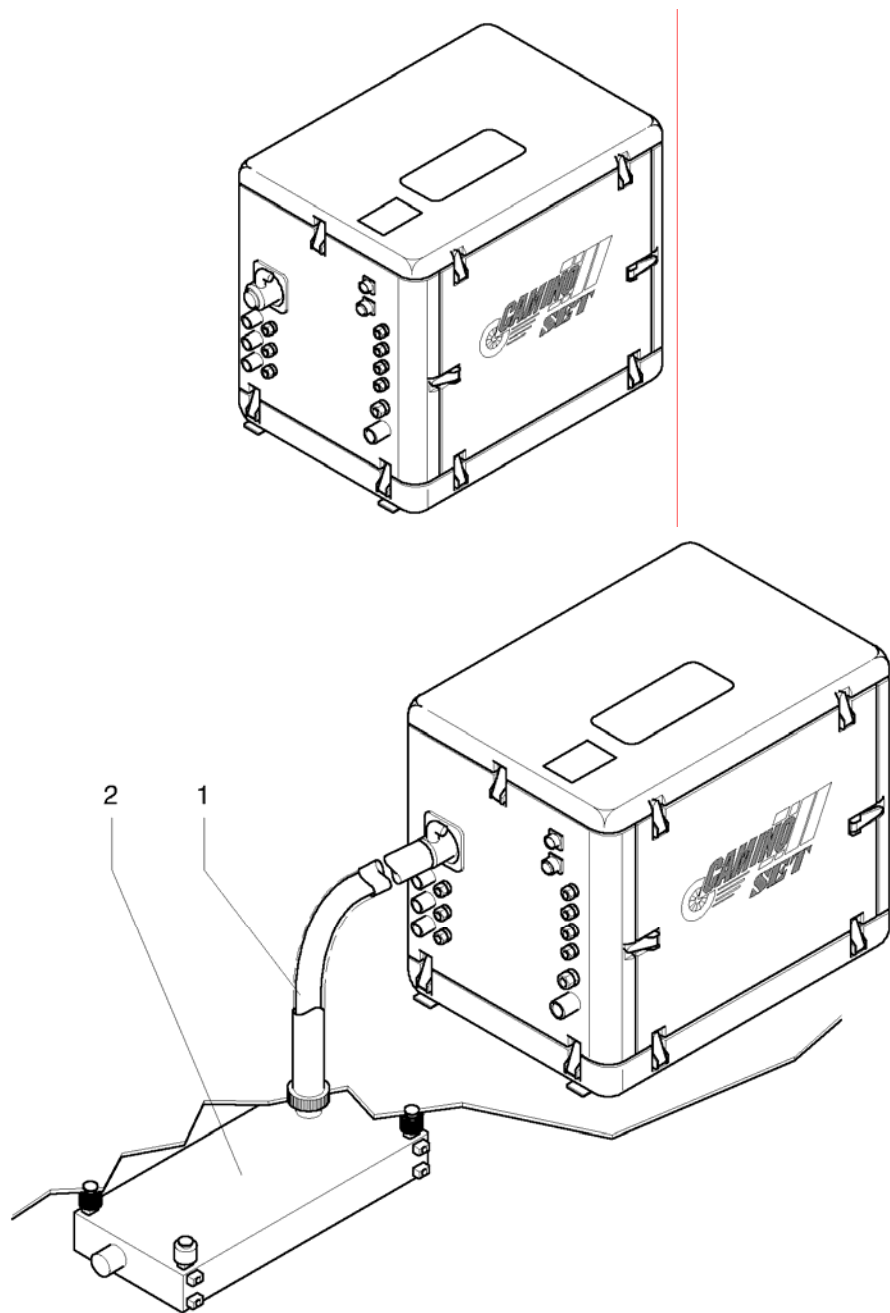

From	to	Type / size
Engine exhaust gas elbow (1)	Exhaust gas silencer (2)	Flexible exhaust gas line Ø ...x ...long



***For the dimensions of the exhaust gas silencer please refer to the dimensional sheet in the Annexes.***

Inlet and outlet of the **SET** exhaust gas silencer (2) can be changed.

#### 4.4.5 External air filter connection (Option)\*

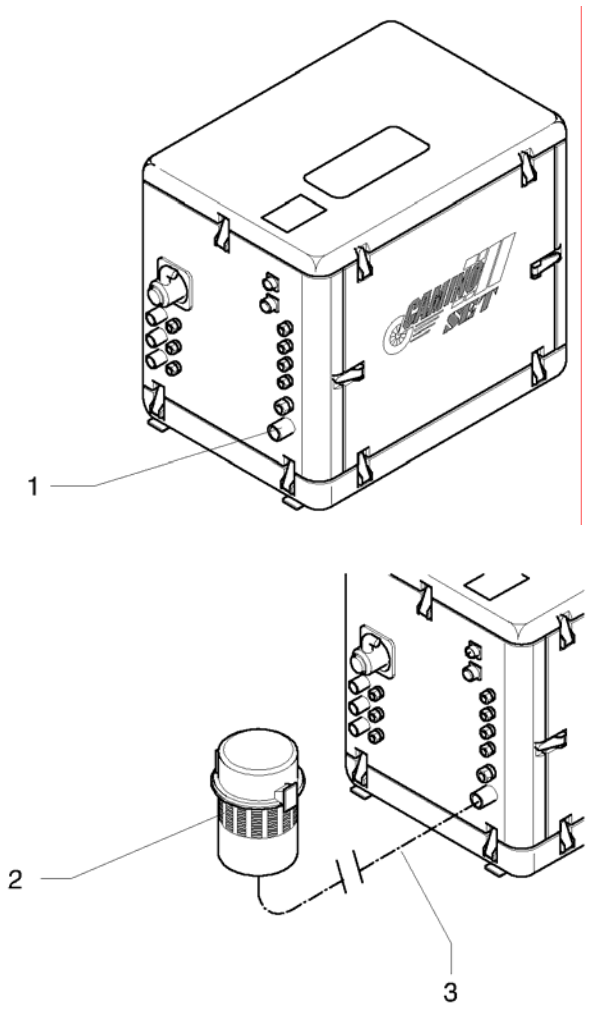

from	to	Type / size
<b>Connection (1)</b> (air connection at housing)	<b>External air filter* (2)</b>	Air hose line (3) Ø 40 x max. 3 m long

\* (if any)

## 5 Installation of the SET Camino Generator

### 5.1 General

This chapter cannot include all possible versions of installation. It deals with the mounting and installation hints (for the application of the **SET Camino Generator** according to the purpose intended) for qualified/authorised specialists.

- In case of doubt, in particular if product specific detail information or accessories to be installed are missing, obtain the relevant information from the specialised workshop authorised by **SET** or directly from the manufacturer **SET**.
- To do so, please always indicate the type designation and production number of the generator (refer also to registration sheet).



***After installation, carry out a check for proper functioning. Make sure that there are no obvious safety defects and risks for the user or environment.***



***The electrical installation shall be started up only by specialised electricians.***

- Have the installation work carried out by a specialised workshop authorised by **SET**.
- No responsibility and liability will be assumed by **SET** for any work carried out by third parties
- Use only admitted and proper materials for mounting and installation.
- It is often the case that later failures are the result of improper installation of the **SET Camino Generator** and the use of inferior materials

## 5.2 Environment

1. The place of installation for the **SET-CAMINO Generator** shall provide sufficient space so that all maintenance points are readily accessible.
2. The ambient temperature at the place of installation or in the room should not exceed 20 °C.
3. Higher ambient temperature will reduce the output of the Diesel engine. If the room temperature exceeds 20 °C, provide for a separate combustion air supply.

The soundproofing hood of the **SET-CAMINO Generator** is provided with a socket where the combustion air must be supplied via the external air filter.

4. At a length of approx. 3 m of the supply line, a diameter 40 mm venting hose can be used.



***The venting hose shall be mechanically resistant and installed without bends, if possible.***

### Insulation

The **SET-CAMINO Generator** is installed in a soundproofing hood and does not require any additional insulation at the place of installation.



***When positioning the generator make sure that maintenance work and checks can be carried out without hindrance.***

***Please test the following after positioning:***

- ***Air filter replacement***
- ***Fuel filter replacement***
- ***Oil filter replacement***
- ***Vee belt replacement***
- ***Coolant bleeding***
- ***Fuse replacement***
- ***Oil check***

### 5.3 Foundation

A solid foundation is required in order to transmit the forces generated by the **SET Camino Generator** to as large an area as possible.

Advantageous foundations and suitable points of the vehicle bottom are the following:

- solid steel plate (approx. 10 mm)
- glued wooden plate
- Screen printing plate min. 30 mm

Avoid cavities below the foundation.

Carefully screw the foundation to the base area.



*The generator has been supplied with a machine frame at which vibration metal elements are mounted. The vibration metal elements prevent solid borne noise from transmission onto the vehicle.*

Dimensions of machine frame:\*

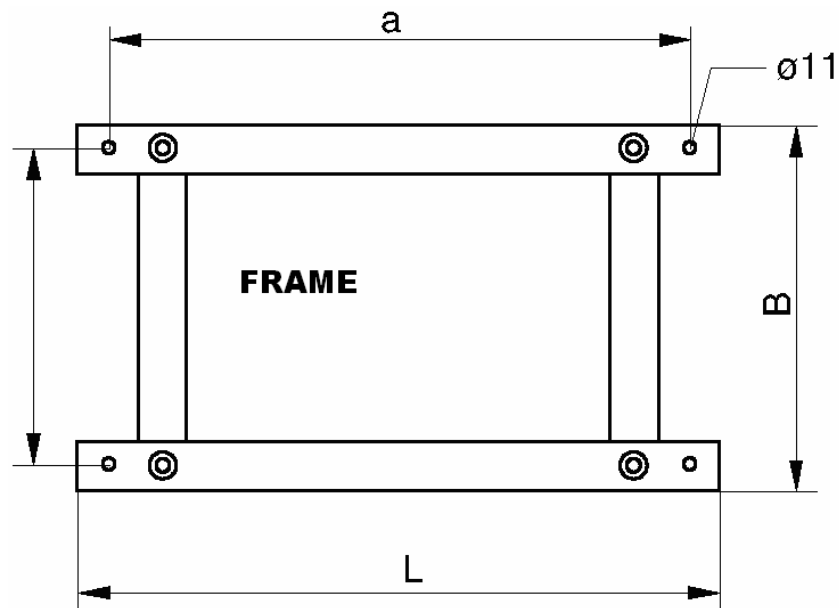

\* (refer also to dimensional sheet and technical data)

## 5.4 Installation of the cooling system



**Install and mount hoses with a sufficiently large radius. Select the place of installation so that sufficient cooling air can flow through.**

The complete cooler unit is pre-assembled.

- The maximum distance between the generator and the cooler unit should not exceed 5 m!
- Height difference max. 3 m above and below the generator.

Components and materials:

1. Cooler unit
2. Cooler hose  $\varnothing$  18 with hose clips  $\varnothing$  15-20
3. Cooler hose  $\varnothing$  115 with hose clips  $\varnothing$  15-20
4. expansion vessel

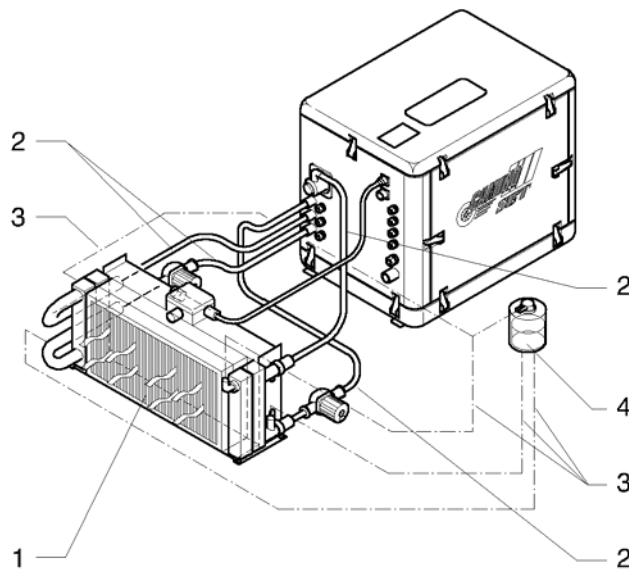

**Use only pressure and suction resistant hoses for temperature up to 100 °C, refer also to SET accessories.**



**Make sure that the axial ventilator in the cooler unit is supplied with sufficient fresh air. Insufficient cooling may result in cooling problems due to which the engine may switch off due to over-heating.**

- Exhaust air opening = cooler size\*.
- The fresh air opening for the axial ventilator shall have at least the 1.2fold area of the exhaust air opening.
- If the exhaust air and fresh air openings are lines (e.g. louvres), make sure that the cooling air can flow in/out without hindrance, increase the exhaust air opening, if necessary.

\* (refer also to dimensional sheet and technical data)

5.4.1 Direction of delivery of the coolant

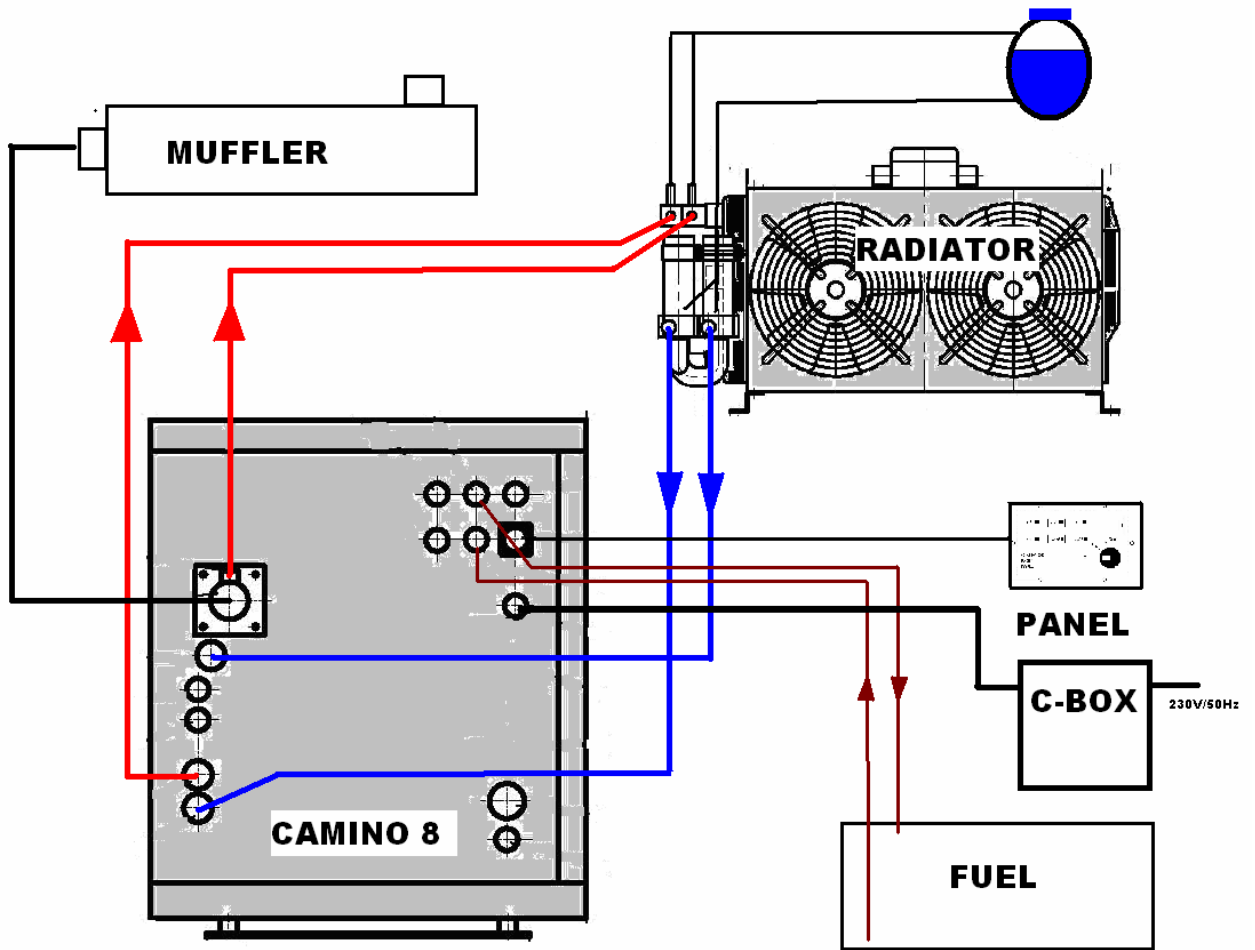

	From	via	to
•	Generator cooler supply line	Hose 15mm	Generator supply line
•	Generator return line	Hose 15mm	Generator cooler return line
•	Engine cooler return line	Hose 18mm	Engine supply line
•	Engine return line	Hose 18mm	Engine cooler return line

### 5.4.2 Piping at the cooling circuit „generator“

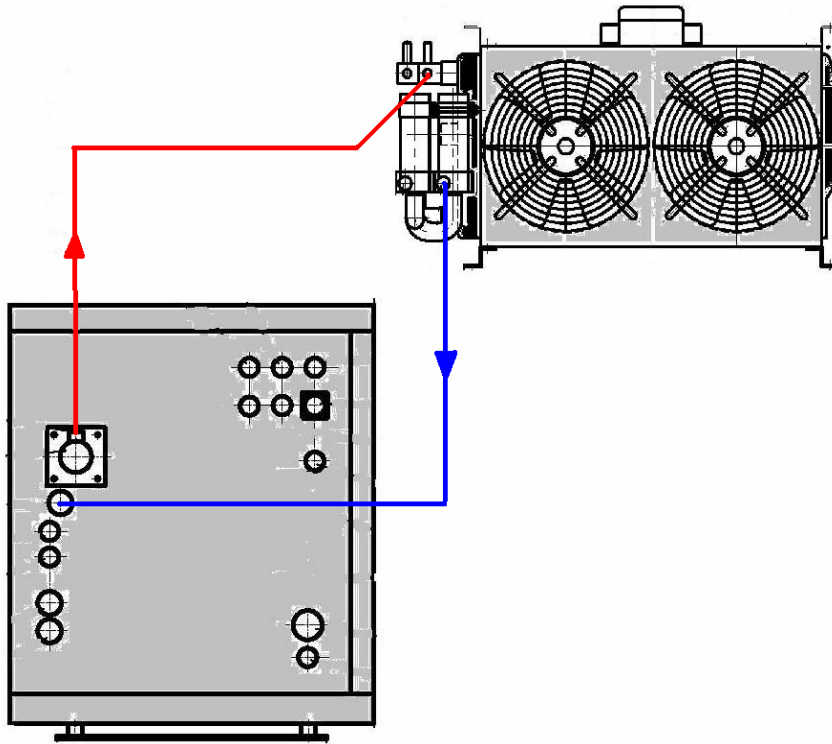

**Generator and exhaust gas cooling** is operated via the closed generator cooling circuit with supply and return lines by means of a coolant pump.

- Mount the **coolant pump** (4) at the supply line (2) of the cooler (1). From the coolant pump to the **supply** socket (6) use hoses\* and/or pipelines. Observe the position of installation of the coolant pump (refer to Figure).
- Connect the piping of the **return line** (3) direct at the cooler. Connect the return line connection (5) at the **SET Camino Generator** housing with the cooler via hoses\* and/or pipelines.



***Hose connections shall be of pressure and suction resistant dia 28 coolant hose and the hose ends shall be mounted by means of suitable clips.***

### 5.4.3 Piping at the cooling circuit „engine“

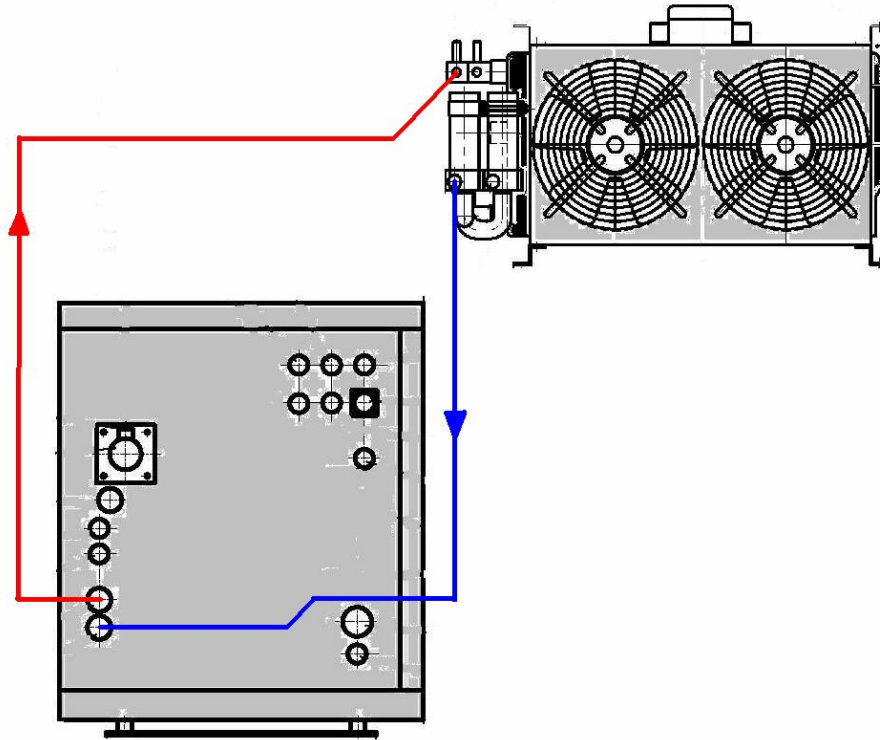

Engine cooling is operated via the closed engine cooling circuit with supply and return lines by means of a coolant pump.

- Mount the coolant pump (4) at the supply line (2) of the cooler (1).  
From the coolant pump to the supply socket (6) use hoses\* and/or pipelines. Observe the position of installation of the coolant pump (refer to Figure)
- Connect the piping of the return line (3) direct at the cooler.  
Connect the supply line connection (5) at the **SET Camino Generator** housing with the cooler via hoses and/or pipelines.



***Hose connections shall be of pressure and suction resistant dia 28 coolant hose and the hose ends shall be mounted by means of suitable clips.***

#### 5.4.4 Piping „expansion vessel“

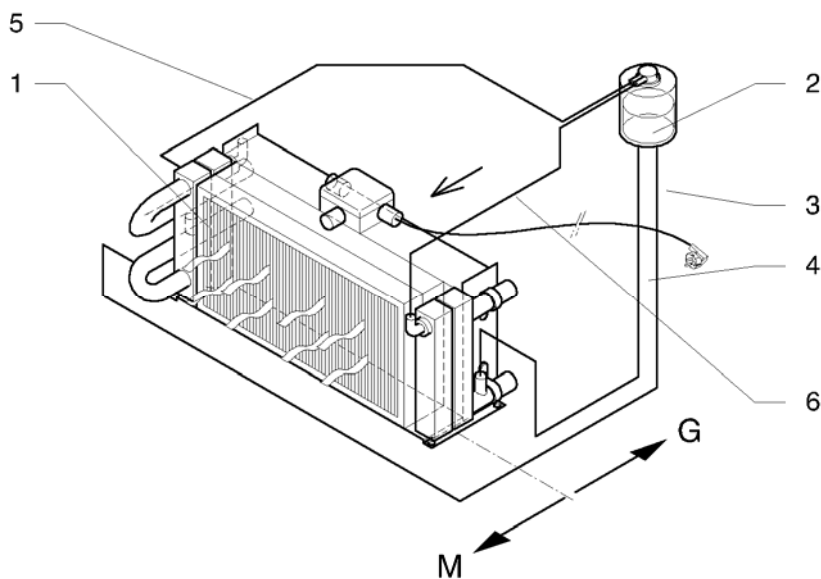

Position the **expansion vessel** on top of the highest point of the whole cooling system at a readily accessible/visible place.

Attach an expansion vessel (2) at the cooler unit (1) as shown in the Figure. It is used to top up and (visually) check the coolant daily.

Connect the hoses (3+4) and the return line hoses (5+6) at the connections of the generator/engine cooler and expansion vessel provided for this purpose.



***Hose connections shall be of pressure and suction resistant dia 12 mm/dia 28 mm coolant hose and the hose ends shall be mounted by means of suitable clips.***

## 5.5 Installation of external air filter (Option)

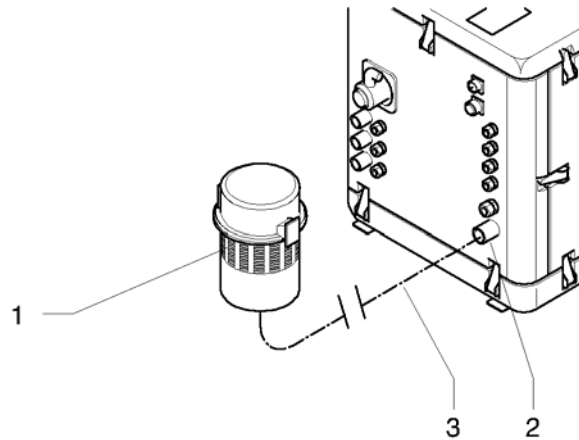

The **place of installation** for the external air filter\* (1) should be selected at a place which is flown through properly by dry air near the **SET Camino Generator**.

Connect the external air filter\* at the socket (2) of the (**SET Camino Generator** housing) via hoses and/or pipes (3).



***Install the hose lines and/or pipings without kinks. Mount the hose ends by means of the enclosed clips. The air filter must not come in contact with road dirt.***

\* The external air filter is not included in the scope of supplies and should be ordered separately, if necessary. The required hose length should also be defined then.

## 5.6 Installation of the exhaust gas system

The **place of installation** of the exhaust gas silencer (1) with exhaust gas line (3) at the **SET Camino Generator** is defined in the order.



**Exhaust gases shall not be taken in by the cooler unit or the air filter. Mount the exhaust gas outlet as far as possible from the cooler unit and the intake slots.**

The exhaust gas line\* should be mounted only as one bend. Any additional bend will cause additional exhaust gas noises. Vibration and temperature bridges to the vehicle bottom are avoided by vibration elements (2).

If necessary, the inlet and outlet openings of the silencer can be changed.

\* The exhaust gas silencer is included in the scope of supplies. However, the exhaust line must be ordered specifically depending on the installation requirements. (refer also to specific **SET** installation rules, if any).

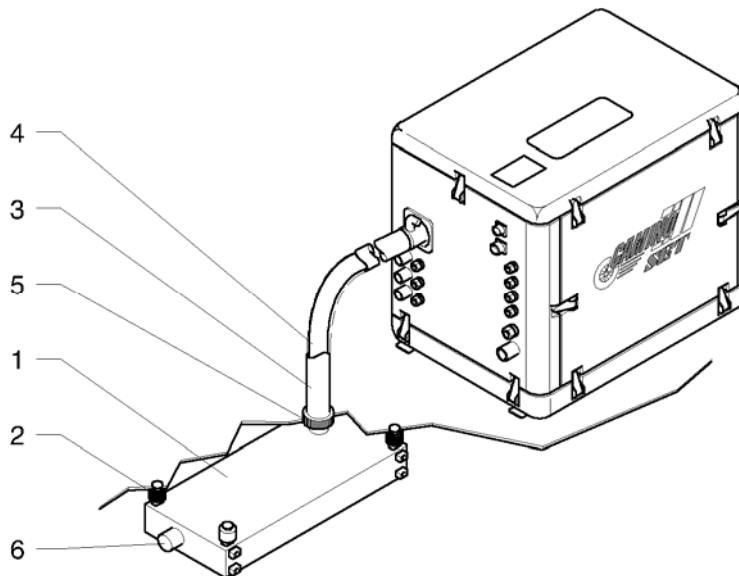

1. Define and mark the place of installation, and drill a through hole (Ø 70 mm) in the bottom of the vehicle, etc.
2. Mount the exhaust gas silencer (1) with the vibration elements (2) at the bottom.
3. Mount the exhaust gas line (3) at the exhaust gas silencer (1) and at the exhaust gas socket of the **SET Camino Generator** housing.
4. Seal the through hole between vehicle bottom and exhaust gas line by means of a steel plate (5).
5. Wrap the enclosed ceramic tape and then wire around the exhaust gas pipe. The ceramic tape protects from burns and vehicle fire.
6. Exhaust gas noise can be reduced further if the outlet (6) of the exhaust gas silencer is extended.

## 5.7 Installation of the fuel system

Installation of the fuel system can be adapted to the local conditions. Follow the specifically described specification when operating it via the vehicle fuel supply system.

The separately working fuel supply system consists of the following:

1. Fuel tank
2. Shut-off cock\*
3. Electrical fuel delivery pump
4. Non-return valve\*
5. Water separator with fine filter\*
6. Supply line
7. Return line

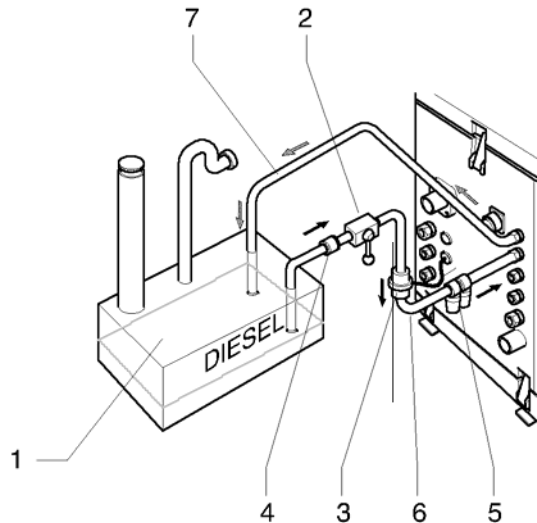

\*not required in any case



***If a Diesel tank is used which was not delivered with the system, use a design approved Diesel tank type. If using a common Diesel fuel tank with the main engine, install an independent connection for the generator with foot-operated valve and ball valve.***



***All components and hoses used must be suitable for Diesel fuel. Install hose lines at a fire-resistant base***



***All metal components and lines of the fuel system must be connected with each other via an equipotential bonding system.***

### 5.7.1 Installation of the separate fuel supply system

Mount the fuel tank (1) so that the low level is on top of the generator. Fuel supply through the descending lines by gravity is ensured in this way.

Install the electrical fuel delivery pump at a distance of min. 2.5 m and/or a height of min. 0.5 m.



*Installation shall be carried out only by specialists qualified/trained by SET.*



*The fuel lines led out of the soundproofing hood of the generator are marked (supply line  $\Rightarrow$ ) and return line ( $\Leftarrow$ ). Make the connections accordingly.*

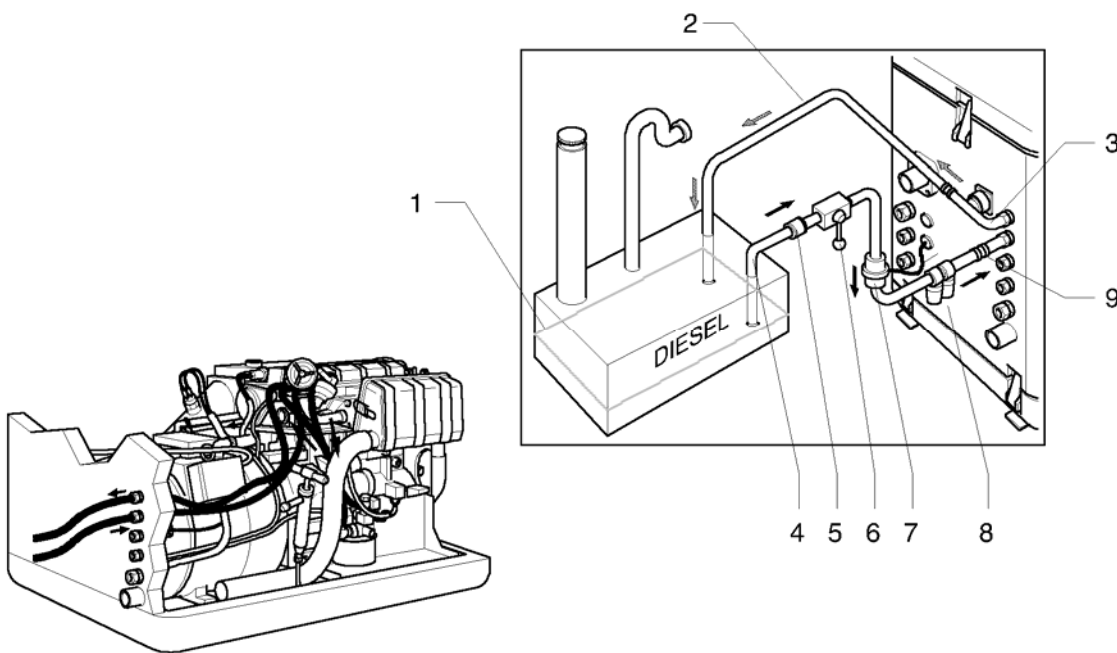

1. Define the place of installation and drill the mounting and/or through holes.
2. Attach the **fuel tank\*** (1).
3. Connect the **return line** (2) direct at the connection line (3) of the **SET Camino Generator**.

4. Connect the **supply line** (4) via Diesel free pipelines/fuel hose NW8 and...
- **non-return valve\*** (5) (...prevents the fuel from returning and thus draining of the supply line)
  - **shut-off valve** ¼" \* (6)
  - **electrical fuel delivery pump\*** (7) (...to be mounted near the Diesel tank)
  - **water separator\*** (8) direct downstream of the electrical fuel delivery pump. Leave sufficient space for filter replacement/cleaning. (From **SET** range of accessories)
- to the **connection line** (9) of the **SET Camino Generator**.

\* (refer also to the documents of sub-suppliers)



***The end of the return line shall end slightly above the tank bottom. Thus the line end is always filled with fuel and the lines are prevented from draining.***



***Prior to start up and on completion of assembly check the whole fuel system for leaks.***

## 6 Electrical installation



**The electrical system shall be installed only by specialised electricians with due consideration given to the rules of electrical engineering.**

### Electrical installation protective measures/Safety



**Follow the protective measures when installing the electrical system!**

Protective measures:



**A residual current protective system for the electrical installation of the SET Camino Generator is mandatory for the safety in the vehicle and near electrical devices and the operator. Its basic function is to prevent dangerous voltages at conductive components of electrical means which might be touched.**

Use of highly sensitive residual current circuit-breakers provides also two other protective functions:



**They protect man and animals even in case of direct contacting live components and prevent fire due to electrical causes.**

### Notes

1. Provide a protective conductor when installing the generator!
2. Earthen the generator by a protective conductor up to the connection terminal of the consumer!
3. Residual current circuit-breakers (FI circuit-breaker = 0.03 A) is required in compliance with the regulations of the manufacturer's country. This requires equipotential bonding from the generator output to the vehicle structure.
4. The regulations of other countries may prescribe other protective measures. Follow the protective measures specified for that country when installing the generator.
5. The company installing the system shall be liable in case of non-compliance.
6. Mount the capacitor housing near the generator.



**Capacitors can withstand a maximum ambient temperature of 70 °C. Prevent heat accumulation in the room. Make arrangements that the air flow to outside be not hindered.**

## 6.1 Installation of control panel



**The control panel is a sensitive electronic unit. Please handle it with care.**

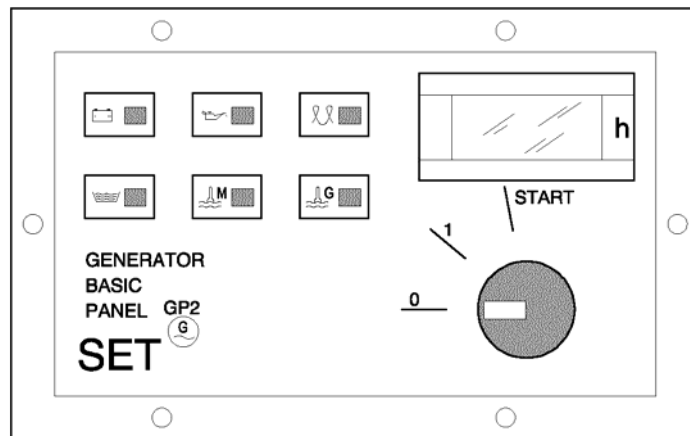

### Sequence of installation of the control panel

1. Install the control panel at a properly visible place.
2. Remove the control panel from the packing.
3. Make the recess for the control panel.
4. Install the supplied 10-core control cable (length 5 m) from the recess to the generator.
5. The control cable is connected at the terminal block of the control panel. (The cores of the control cable are numbered)
6. Connect the plug of the control cable so that it is not distorted and the poles are not confused.



**The terminals of the control panel are mounted directly at the circuit board. Use a suitable screw driver in order to protect the sensitive screws from over-tightening.**

A socket for the connection of the control cable is provided in the soundproofing hood of the generator.



Terminal box

Line 1 = + 12 V

Line 2 = 0 V 12

Line 3 = Starter

Line 4 = Pre-glowing

Line 5 = Fuel

Line 6 = Temperature of engine

Line 7 = Temperature of generator

Line 8 = Oil pressure engine

Line 9 = Battery charge

Legend:

External consumers

Dynamo

Geldruch engine

Temperature generator

Temperature engine

External consumers

Fuel solenoid valve

Pre-glowing relay

Start relay

Field starter

Pre-glowing

Starter

Accumulator

## Connection of the electrical fuel delivery pump

Appropriate connection lines are led out of the soundproofing hood of the **SET Camino Generator** for the connection of the electrical fuel delivery pump.



***The electrical fuel delivery pump is operated at 12 V and connected directly at the cables which are lead out of the generator and which are provided with fuses. The fuel delivery pump shall be connected electrically only by specialised electricians. Risk of short circuit and fire in case of improper connection!***

## 6.2 Connection of main capacitor and main distributor

Connect the capacitor housing – which has been connected to the generator at the manufacturer's – to the main distributor in the vehicle.



**Do not start the generator unless the electrical installation has been completed and tested.**



**Mount the capacitors so that sufficient line length remains to insert the cable in the soundproofing hood. The cable shall not be affected mechanically by vibrations of the generator.**

- Install an intermediate distributor, if necessary.
- Avoid rubbing point when installing.
- Install cables at a fire resistant base or in cable conduits.

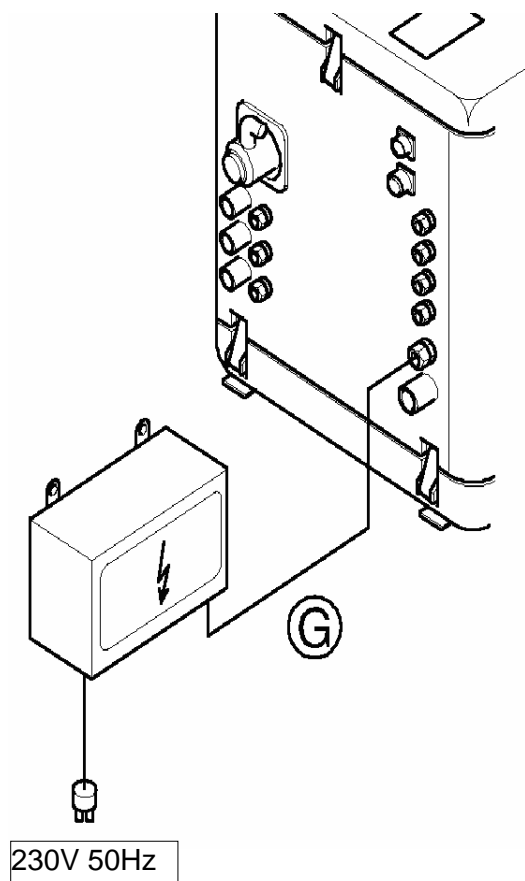

### 6.3 Electrical system of the vehicle

Wiring diagram for the 230 V / 50 Hz wiring from the generator to the electrical system of the vehicle.

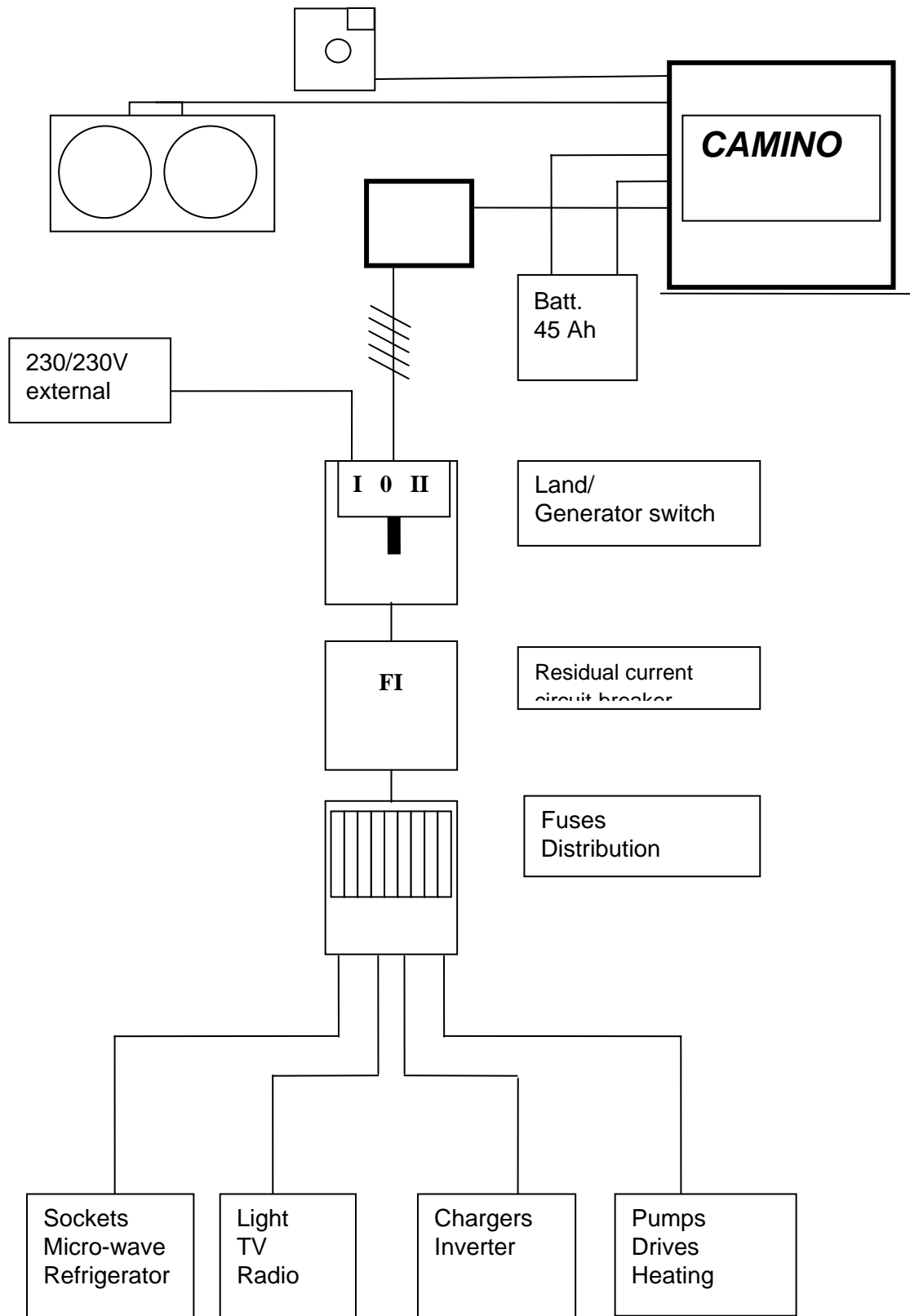

## 6.4 Connection for additional 12 V consumer

One 12 V consumer of max. 3 A can be connected additionally at the existing connection line.

The required fuse (3 A) is installed in the electronic box.

- The connections lines are marked plus (+) and minus (-).
- Connect plus (+) and minus (-) of the electrical fuel pump (3) with the connection line (4).

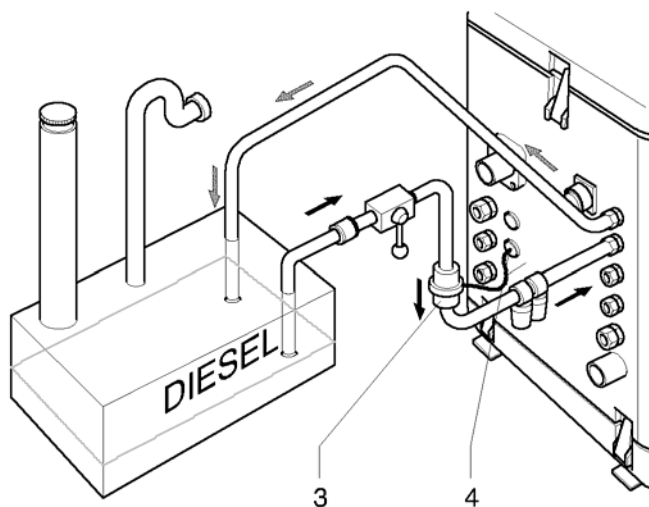

***If the generator is operated with automatic options, install also a generator safeguard. All live lines are separated then. The generator safeguard can also be combined with delayed pull-up. Installation of generator safeguards***

## 6.5 Mounting and installation of the starter battery

The 12 V starter battery (> 45A <88Ah) is charged continuously during the operation of the **SET Camino Generator**. It shall be mounted and fixed near the pole cable (3 + 4).

If installation within reach is not possible, use special lines\* with a higher cross-section.



**To low a line cross-section may cause fire and malfunction when starting the generator.**

Protective battery housings\* (not shown) protect you and your vehicle and are recommended as:

- Protection from moisture.
- Protection from mechanical damage.
- Protection from leaking electrolyte.



**The SET Camino Generator shall be provided with an independent starter battery to start the driving engine. No other consumers shall be connected with that battery.**

Insert/mount the battery connection cables (3) which are lead out of the **SET Camino Generator** (and earth (4) direct at the relevant pole terminals of the starter battery (2).

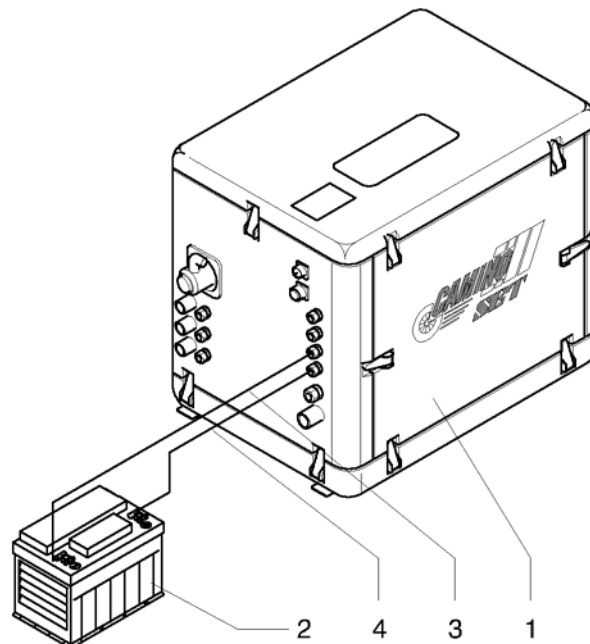

\* (refer to **SET** range of accessories)

### General notes for installing the starter battery



***Batteries discharge automatically and shall thus be serviced and maintained properly. The higher the quality of the battery the lower the factor of self-discharge.***

- Mount the battery only at a suitable place.
- Mount the battery/protective battery housing\* so that it is protected from shocks and tilting.
- Install the battery cable – according to the cable length – at a fire resistant base or in an appropriate cable duct.
- When installing make sure that the pole shoes of the lead out cable ends can be connected with the relevant poles of the battery.



***Do not connect the battery unless installation and assembly of the generator systems are completed.***

## 7 Initial start-up

On completion of assembly and installation of the **SET Camino Generator** follow the following steps for initial start-up in any case:

Check in the following order:

1. Check the whole mechanical and electrical installation.
2. Check Diesel fuel level in tank, top up, if necessary.
3. Open shut-off cock at Diesel tank.
4. Check fuel system for leaks.
5. Check coolant level in cooler unit, top up, if necessary.
6. Check oil level of engine, top up, if necessary.
7. Plug of cooler ventilator connected.
8. Key-operated switch at control panel in „0“ position.
9. Plug of control line connected.
10. Connect starter battery (observe correct polarity).
11. Turn mains/generator switch to „0“  
(generator must not start with load).



***When connecting the battery observe the correct polarity. The cables led out of the SET Camino Generator are marked (+) and (-). Connect the cables according to the battery.***

## 7.1 Coolant filling

### Prior to starting the SET Camino Generator

Fill cooler:

1. Unscrew plug at expansion vessel.
2. Fill coolant in the expansion vessel until coolant becomes visible.
3. Bleed at the water-cooled exhaust gas elbow (1) at the system bleeding screw (2).
4. Tighten plug.
5. If necessary, bleed the cooling circuits directly downstream of the pumps.

### After starting

1. Start the **SET Camino Generator**.
2. Top up coolant in the expansion vessel.
3. Check the cooler ventilator for proper operation.

If the first start was not successful, turn control panel to „OFF“ and wait for approx. 5 s.

Then start again.



**Look for leaks (re-tighten hose clips).**

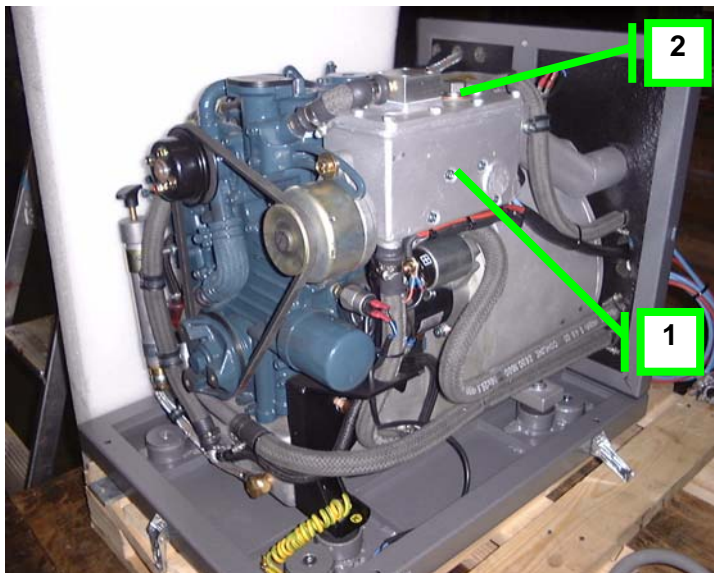

1. Water-cooled exhaust gas elbow
2. Bleeding screw

## 7.2 Operation

### General

Operation of the generator is very easy and no specific technical requirements must be met by the operator.

However, you should follow some basic hints:

- The **SET Camino Generator** is installed in a soundproofing hood and cannot be heard by you under certain circumstances.
- Hence observe the displays of the control panel during operation.
- Check the coolant level in the expansion vessel on top of the cooler unit.





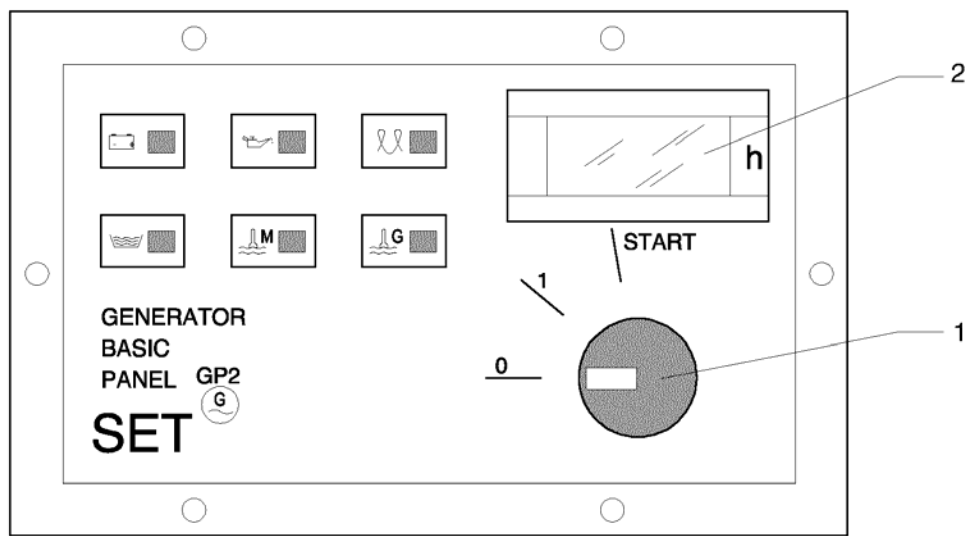

## 7.3 Start-up

Subject the **SET Camino Generator** to a visual inspection.



1. Open the housing - hood.
2. Check housing for moisture traces and eliminate leaks, if any.
3. Close and lock the hood - housing.
4. Check fuel system for leaks.
5. Check level of Diesel fuel in tank.
6. Open fuel shut-off valve at tank.
7. Check cooling water system.
8. Check coolant level (expansion vessel) of cooler unit, top up, if necessary.
9. Ensure fresh air supply to cooler unit.
10. Check electrical system.
11. Turn main (mains)/generator switch in position „0“.
12. Switch off all additional consumers (for installations only without generator safeguard).
13. Start the **SET Camino Generator**.



Display      Function / explanation

1	0 - 1 - Start	Key-operated switch
2	(h)	Sum of accumulated operating hours
	Green LED... Red LED....	If battery <b>is charged</b> If the <b>charging process is interrupted</b>
	Green LED... Red LED....	If the <b>oil pressure is OK</b> if <b>oil pressure is missing</b> (switches off engine automatically)
	LED lights up ...	As long as the <b>pre-glowing time 15 sec.</b> runs (start is allowed then)
	Green LED... Red LED....	If the inside of the housing is <b>dry</b> If <b>water</b> is in the soundproofing housing (switches off engine automatically)
	Green LED... Red LED....	If <b>engine temperature is OK</b> If <b>engine temperature exceeds 95°C</b> (switches off engine automatically)
	Green LED... Red LED....	If <b>generator temperature is OK</b> If <b>generator temperature exceeds 95°C</b> (switches off engine automatically)

### 7.3.1 For initial start proceed as follows

1. Turn key-operated switch in position „ 1 “.
2. The control LED  pre-glowing lights up, pre-glowing time approx. 15 sec.
3. Pre-glowing LED  extinguishes.
4. Turn key-operated switch in position „ **START** “. Diesel engine of generator starts (start phase < 3-4 sec.).



***If the Diesel engine does not start immediately, wait for approx. 5 s and repeat starting.***

If the red LED  „battery“ flashes, the generator does not supply a sufficiently high voltage

- LED  „battery“ changes from RED to GREEN :
- Diesel engine reaches its rated speed.
- Generator supplies its rated voltage (230 Volt).
- All monitoring LED light green.



***Prior to loading the generator by electrical consumers check the coolant level in the expansion vessel.***

Now the generator can be loaded with electrical consumers.

Turn main switch\* (mains/generator switch) in position „2“.

- Connect the consumers (for loading refer to the nameplate).
- Switch off the generator in case of unclear troubles. (refer also to operating manual/Failure, elimination of failures, repair)



***Do not operate the generator continuously in short-time mode but mainly in continuous mode under load.***  
(refer also to documents of engine manufacturer)

\* (if any)

## **8 Installation documents of sub-suppliers**

**8.1 Sub-supplier documents - General**

**8.2 Sub-supplier documents - Engine**

**8.3 Sub-supplier documents - Generator**

**8.4 Sub-supplier documents – Electrical/control system**

**8.5 Sub-supplier documents – Cooling system**

**8.6 Sub-supplier documents – Tank system\***

**8.7 Sub-supplier documents – External air filter\***

**8.8 Sub-supplier documents – Exhaust gas system**

\* (if any)

Documents in Annex